

iFlex



TABLE OF CONTENTS

- 1. Plan the installation..... 3
 - 1.1. Working hose lenght 3
 - 1.2. Valve locations - Power Unit Selection 3
 - 1.3. Plan pipe runs 3
- 2. How to start 4
 - 2.1. Valve assembly 4
 - 2.2. Determine Valve Height – Down orientation..... 4
 - 2.3. Determine Valve Height – Up orientation 5
- 3. Installation the inlet 5
 - 3.1. Installation the inlet in the brickwall 5
 - 3.2. Installation the inlet in the plasterboard 6
- 4. Installation pipeline iFlex 7
 - 4.1. Instruction and advice for installing pipeline 7
 - 4.2. Design the pipe runs..... 9
 - 4.3. Path of piping on the same level.....10
 - 4.4. Path of the piping on different levels.....11
 - 4.5. Typical diagram of floor piping12
 - 4.6. Typical diagram of suspended ceiling piping.....13
- 5. Low voltage electrical connection14
- 6. Door iFlex Installation.....15

1. Plan the installation

Planning is the key of a successful installation of a central vacuum system iFlex. A balance between the best locations for the inlet valves and the practicality of installing in these locations is essential. With a little ingenuity, most locations can be reached.



Warning

This manual assumes that the installer has working knowledge and experience installing traditional central vacuum systems. It is critical that only parts designed for the iFlex retractable hose system be used in the installation.

The iFlex piping and its fittings have a diameter of 2".

DO NOT USE PIPING Ø50mm.

I Failure to use these parts will void any warranty offered by the manufacturer.

1.1. Working hose length

The length of the hose is 12m, the tube can also be locked at a shorter length using the appropriate lock in the iFlex inlet. For the sizing of the number of inlet points and the choice of location of the inlets iFlex vacuum therefore need to consider a working hose length 12m. Any time you should not cover all the rooms assuming a 12m pipe, insert a further outlet point or evaluate a new location of the iFlex inlet.

1.2. Valve locations - Power Unit Selection

It is important to keep in mind that air flow is reduced with longer hoses. To compensate for the loss of air flow, a larger power unit is required.

In fact, in traditional systems, flexible working tubes are generally used 7m or 9m.

To compensate for the loss of air flow and to allow the tube to be retracted effectively, a more powerful suction unit is therefore required. Below is a table where the maximum number of socket points and the maximum curves that can be used with the Wi1450 station model are summarized:

Number of valves	Max num. of curves	Mod. Retractable Hose System
1	n.3 90° curves + n.2 45° curves	WS/Wi1000 Plus - WS/Wi1250
2	n.3 90° curves + n.2 45° curves (for each valve)	WS/Wi1000 Plus - WS/Wi1250
3	n.3 90° curves + n.2 45° curves (for each valve)	Wi1450
4	n.3 90° curves + n.2 45° curves (for each valve)	Wi1450
5	n.3 90° curves + n.2 45° curves (for each valve)	Wi1450

1.3. Plan pipe runs

Carefully read the "pipe runs" section of this guide. In this chapter there are diagrams of typical systems where it is possible to verify how to install the system in a workmanlike manner and all the errors to be avoided.

For any doubts and / or further specifications, contact the Technical Office.

2. How to start

Before proceeding with the installation of the iFlex system it is advisable to decide on the type of orientation required.

2.1. Valve assembly

The iFlex box is the most compact on the market and has an excursion max of 15mm to best adapt to uneven surfaces or different thicknesses of plaster. The following are the overall dimensions:



2.2. Determine Valve Height – Down orientation

Down Orientation

If the inlet is to be installed in a downward orientation (hose comes out from the bottom), we recommend that the bottom of the inlet be installed between **a at a height of 70 cm, without going lower than 50 cm to the floor,** for maximum ease of use.

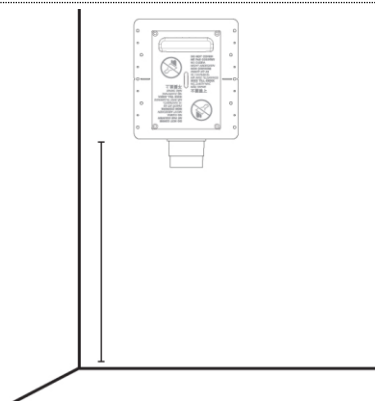

2.3. Determine Valve Height – Up orientation

Upward Orientation

In an upward orientation (hose comes out from the top), we recommend that the bottom of the inlet installed between a **at a height of 110 cm, without going lower than 100 cm to the floor**, for the maximum ease of use.

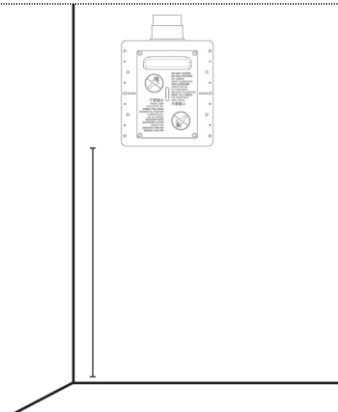

3. Installation the inlet

The iFlex inlet can be installed both in masonry walls and in plasterboard walls. Below is some information for a correct installation for both solutions.

3.1. Installation the inlet in the brickwall

Connect the white piping in 2" to the socket and connect in the appropriate back base the corrugated wire for the connection to the low tension, then seal the hole with plaster.

Then fix the iFlex socket in the wall, keeping the yellow cover outside the plaster line.



Make sure that taking off the yellow protection cover (thickness 1 cm) the socket does not protrude from the plaster line.

The yellow cover has to be external to the plaster line. The plaster line has to stay inside the thickness of 1 cm of the yellow cover.

ATTENTION: Do not exceed the plaster line over the yellow cover.

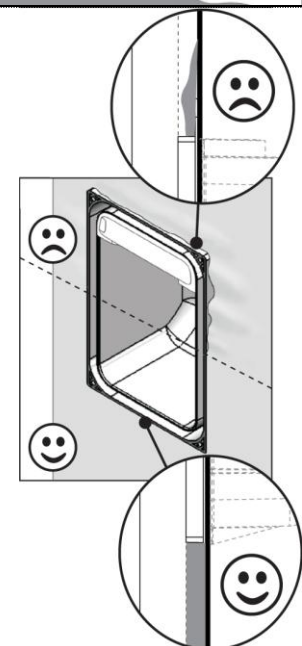

3.2. Installation the inlet in the plasterboard

Fix the frame to the support in aluminum ❶.
Make sure that the inlet is levelled and that there is space of 7,6 cm behind it.

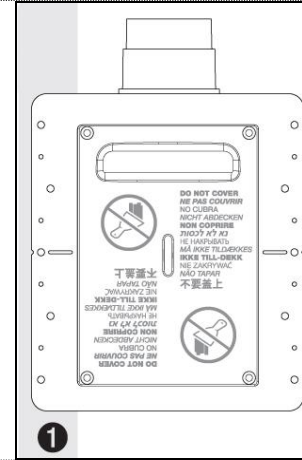

We recommend to add another stud ❷ on the other side to secure the inlet in place.

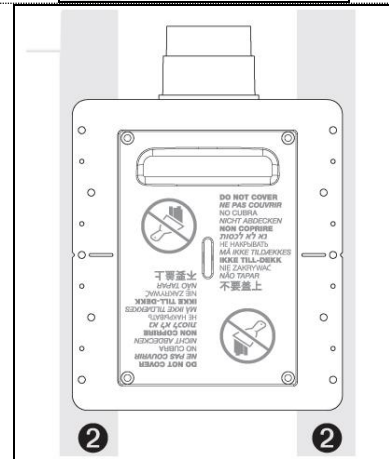

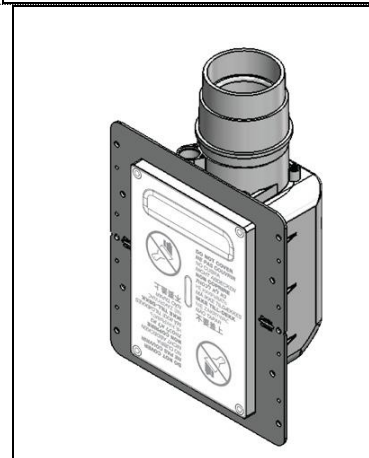

Connect the white piping in 2" to the socket and connect the corrugated wire in the appropriate back base for the connection to the low tension.

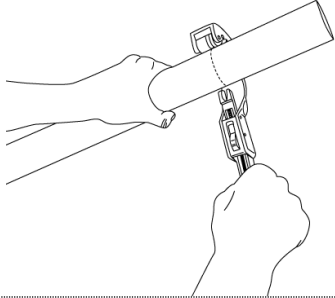
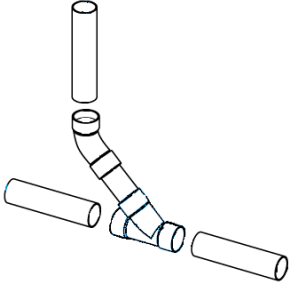

4. Installation pipeline iFlex

4.1. Instruction and advice for installing pipeline

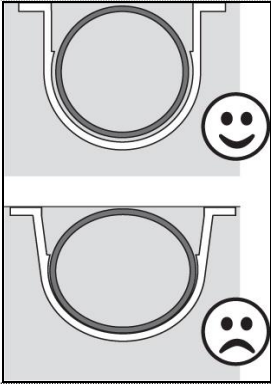
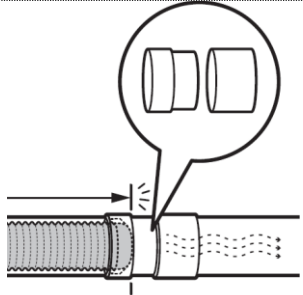
<ul style="list-style-type: none"> • PVC pipes must necessarily be cut with a specific pipe cutter, cleaning up any excess burrs, without ever using a hand saw 	
<ul style="list-style-type: none"> • Always respect the air flow 	
<ul style="list-style-type: none"> • <u>The piping of the predisposition always has to be longer than the flexible hose used. We suggest minimum 50 cm of white piping 2" more than the length of the flexible hose</u> 	
<ul style="list-style-type: none"> • When installing the pipe straps to secure the piping in place, make sure not to squeeze the pipes, so as not to alter the movement of the hose inside the piping system. 	
<ul style="list-style-type: none"> • Add the safety stopper before connecting to the blue piping in 50 mm. It has to be placed in the point consequently minimum 50 cm after the length of the flexible hose. Note: The safety stopper avoids that the flexible hose can accidentally retract too much in the piping. 	

- The reduction from 2" to Ø50mm has to be installed directly in the red stopper and after it, before passing to the piping with diameter 50 mm that will be connected to the vacuum central.

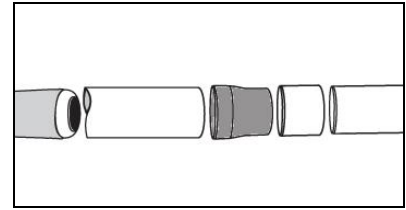

- It is necessary to glue the PVC pipes, carefully cleaned, and the fittings only on the "male" part, with the specific General D'Aspirazione adhesive and using a special spreader
- ATTENTION: NEVER PUT GLUE IN THE FEMALE FITTING.



- If the inlet is installed upwards and the pipe runs straight up for 3 m or more, add two 22.5° elbows close to the inlet iFlex to keep the flexible hose slows down during its extraction.

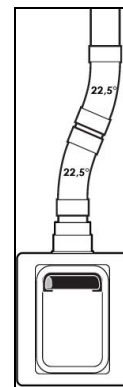

- Only use fittings designed for the iFlex system

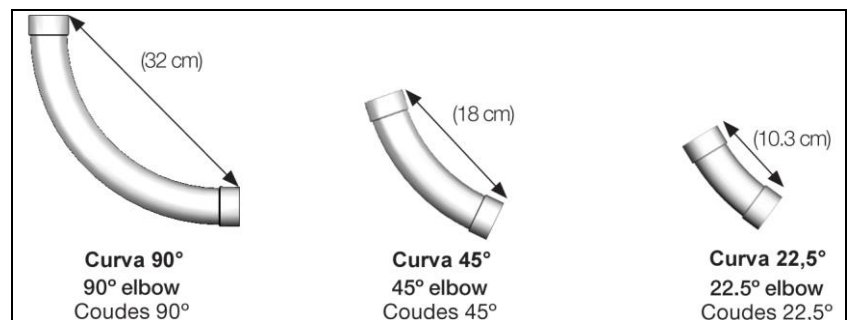

4.2.Design the pipe runs

For a correct installation follow these guidelines:

- You can use up to 4 elbows of 90° for every inlet without using other fittings. Alternatively, you can use 3 elbows of 90° + 2 elbows 45°.

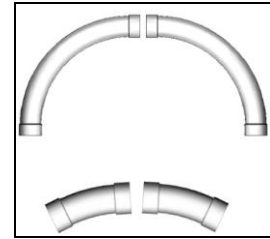

- When it is possible to try to avoid the installation of 90 ° bends close together. We recommend always installing at least one meter of pipe between a 90 ° bend and the next. We advise to install always at least 1 metre of pipe between 1 elbow and another.

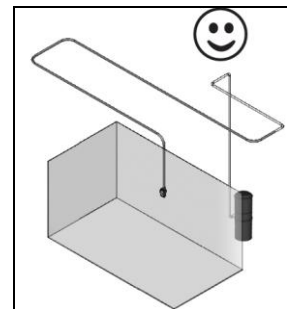

- It is important to design the pipe runs so the hose is contained on one level.
- Avoid to contain hose on two different levels.

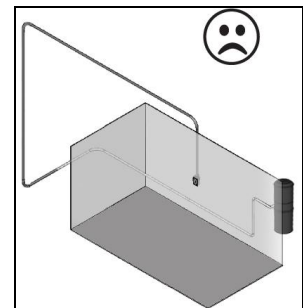

4.3. Path of piping on the same level

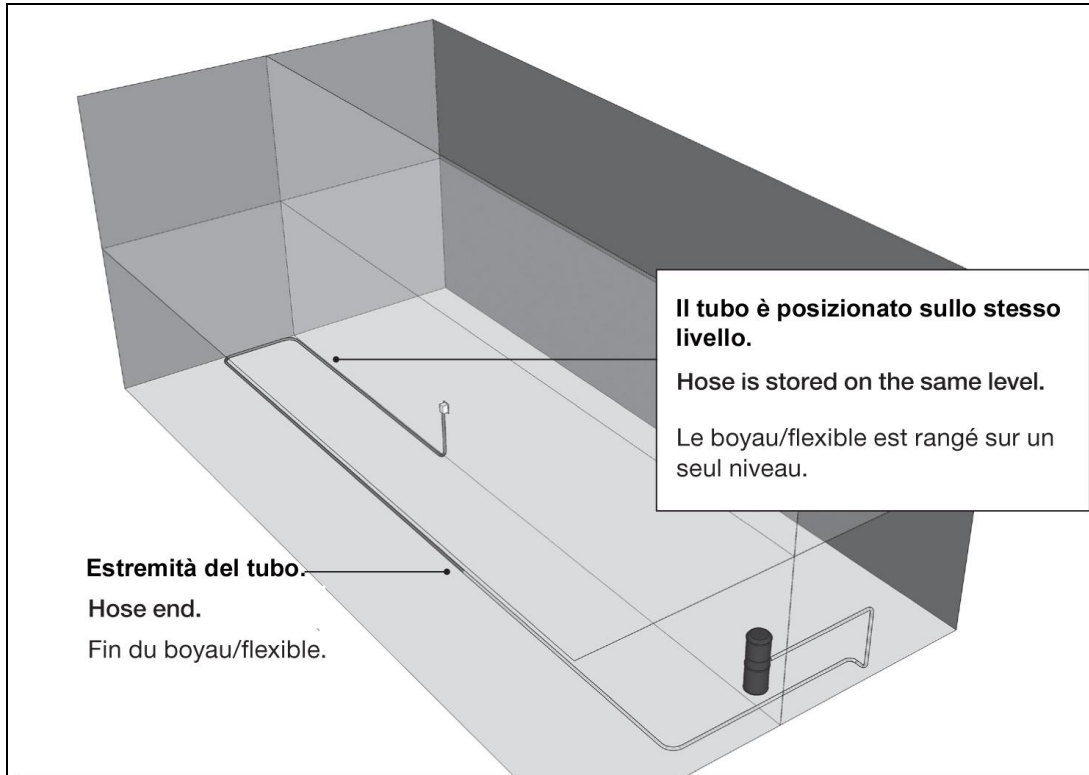

Orientamento verso il basso | Down Orientation | Orientation vers le bas

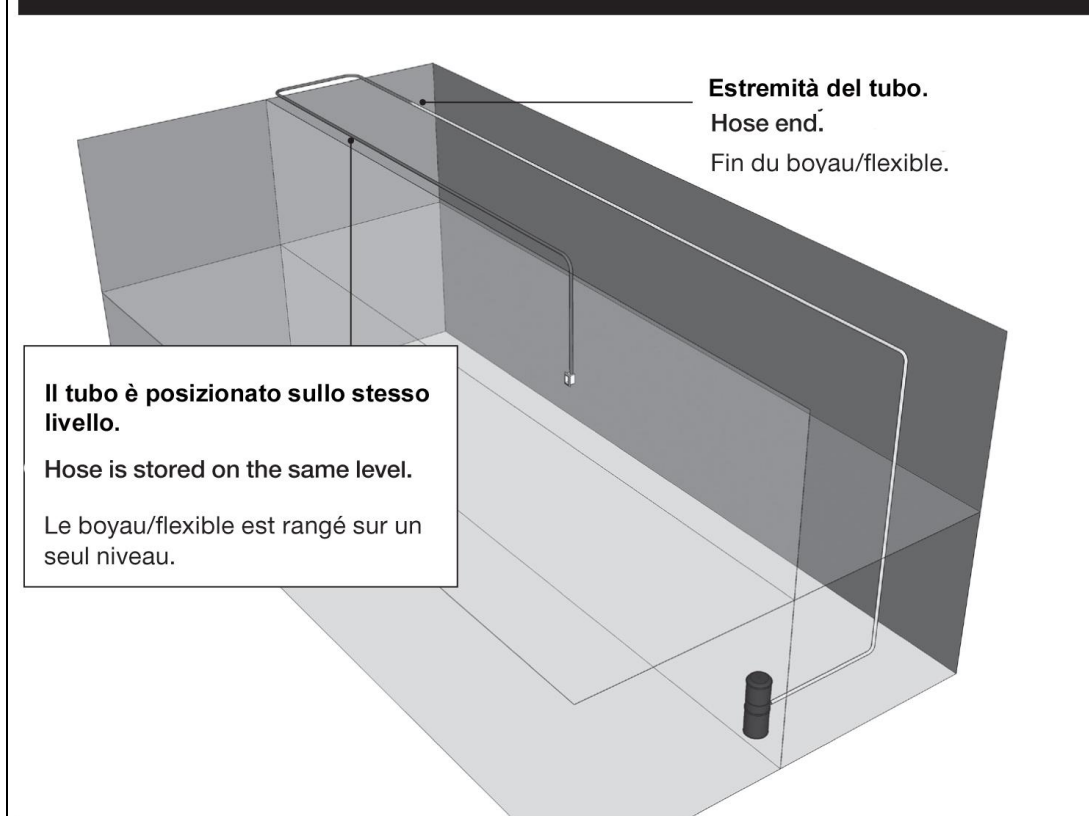

Orientamento verso l'alto | Up orientation | Orientation vers le haut

4.4. Path of the piping on different levels

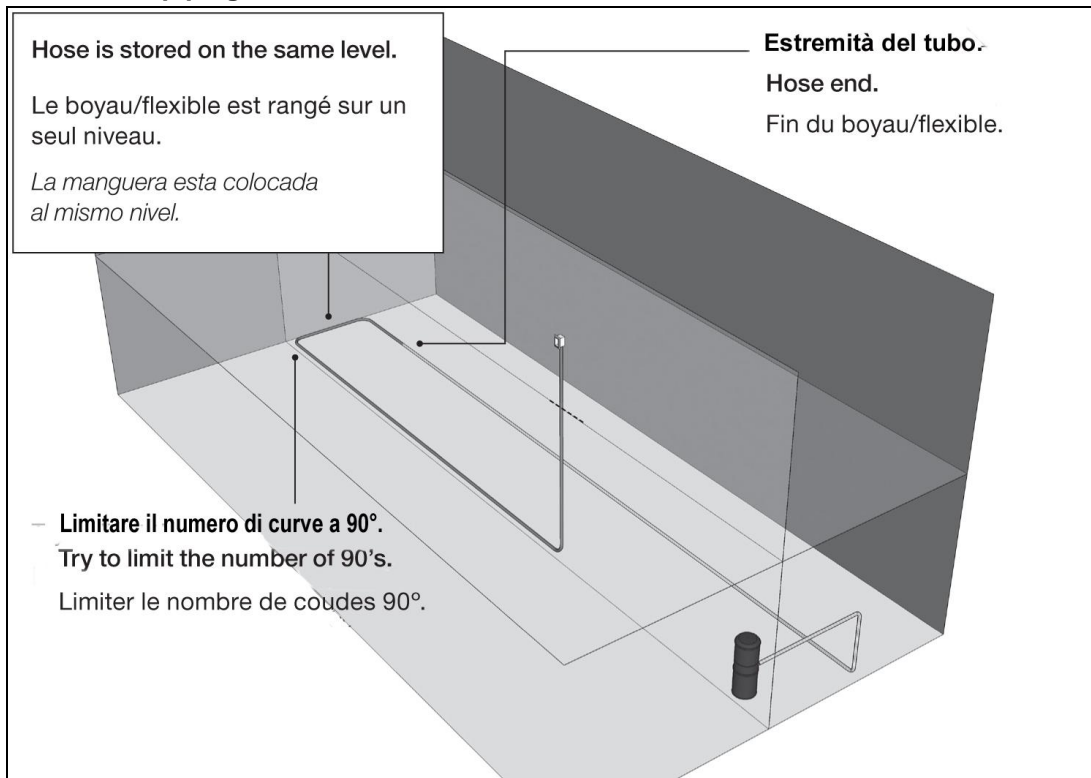

Orientamento verso il basso | Down Orientation | Orientation vers le bas

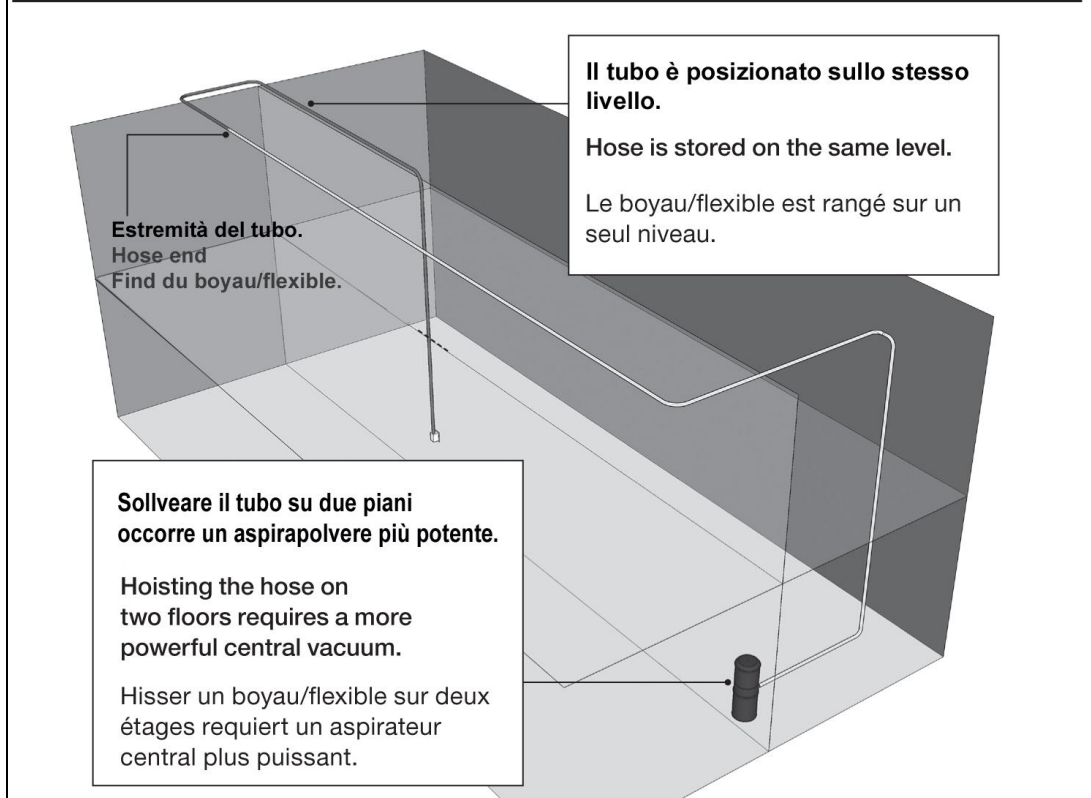

Orientamento verso l'alto | Up orientation | Orientation vers le haut

4.5. Typical diagram of floor piping

In order to ensure a sufficiently long pipe to house the flexible pipe it may be necessary to lengthen the pipe before reconnecting with the central vacuum unit.

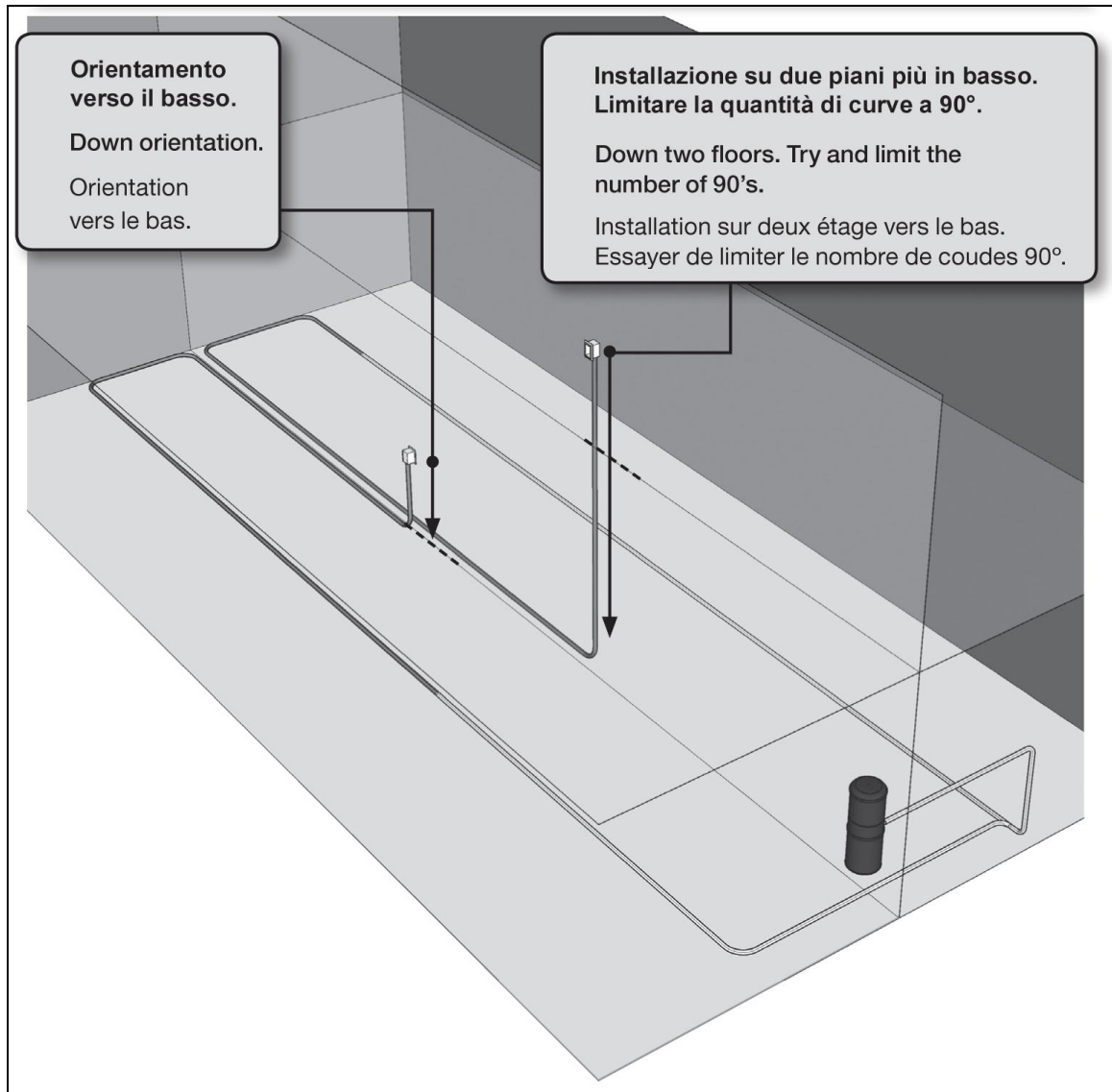

4.6. Typical diagram of suspended ceiling piping

In order to ensure a sufficiently long pipe to house the flexible pipe it may be necessary to lengthen the pipe before reconnecting with the central vacuum unit.

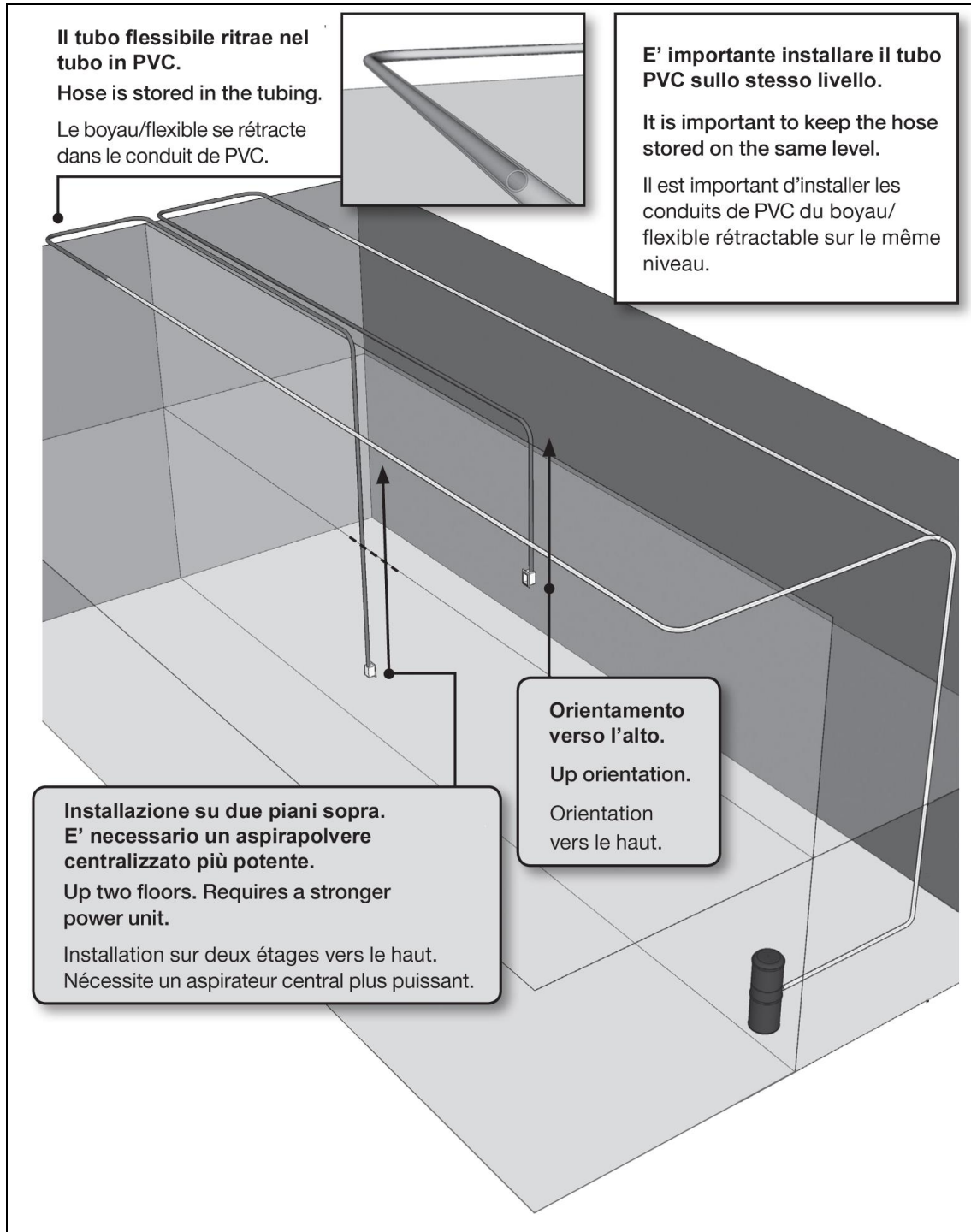

5. Low voltage electrical connection

Install the low-voltage wire of the vacuum sockets just like in a traditional system. For wireless systems it is not necessary to prepare the electrical connection.

- Connect the two contact wires of the iFlex suction inlet to the low voltage line of the control unit

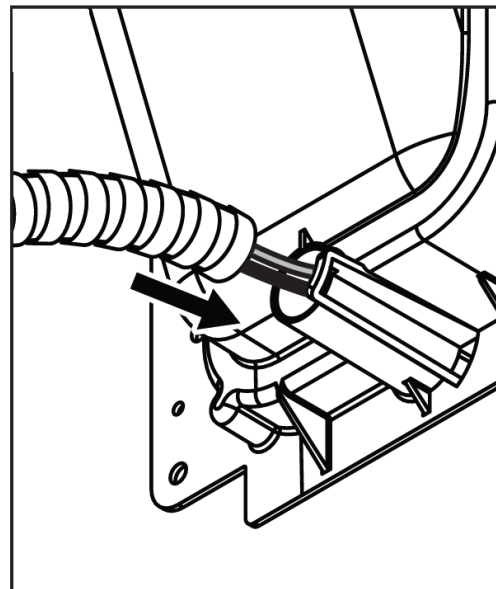

- Carry out the electrical connection using a pre-threaded 2x1 flex pipe exactly as in standard civil applications. The iFlex inlet has a dedicated predisposition for low voltage electrical connection.

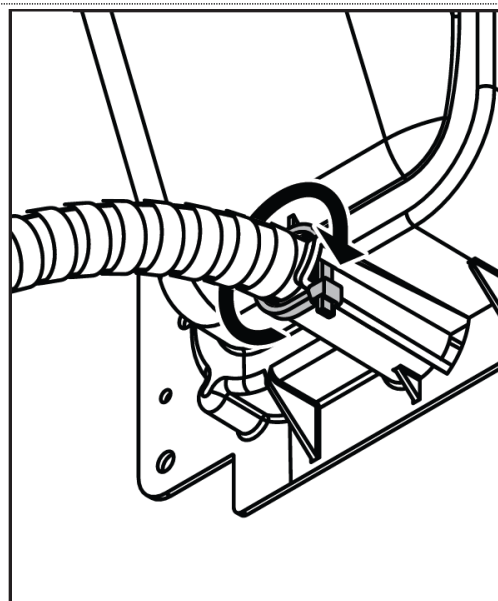

WARNING:

After completing the low voltage electrical connection, carry out a test to verify the correct operation of the electrical contact before closing the wall. It is also recommended to carry out a system leak test before proceeding with the closure of the wall.



General D'Aspirazione s.a.s.

via del lavoro, 9/11

47030 San Mauro Pascoli (FC)

Tel. +39 0541 931012

info@generaldaspirazione.com

www.generaldaspirazione.com