

Manual of use and maintenance

Rev. 19-01

INFINITY WIRELESS SYSTEM

IWS



**GENERAL[®]
D'ASPIRAZIONE**
IMPIANTI ASPIRAPOLVERE CENTRALIZZATI

MADE IN ITALY

INDEX

| | | |
|------|--|---|
| 1. | General safety information | 2 |
| 1.1. | Purpose of Manual | 2 |
| 1.2. | Composition of the manual and consultation details | 2 |
| 1.1. | Manufacturer's identification | 3 |
| 1.2. | Recommendations for use | 3 |
| 2. | Product description | 4 |
| 2.1. | How it works..... | 4 |
| 3. | Installation | 5 |
| 3.1. | Installation of the Master Unit | 5 |
| 3.2. | Installation of Slave Unit | 6 |
| 4. | Configuration and Programming | 7 |
| 4.1. | Programming of the Brava Wireless Handle | 7 |
| 4.2. | Reset delle impugnature Brava Wireless | 7 |
| 5. | Put out of service and disposal..... | 8 |
| 6. | Product guarantee | 8 |
| 7. | Declaration of EC Conformity | 9 |

1. General safety information



Read this manual carefully before starting the operations of handling, unpacking, installation, use, maintenance and put out of service of the IWS System.

1.1. Purpose of Manual

The manual of installation, use and maintenance is integral part and essential of the IWS System. It's designed to provide all the information necessary to enable the installer to perform the installation in accordance with criteria established by the manufacturer, the user is able manage the system in the most independent and safe as possible and the technicians maintainers perform the planned operation for the good functioning of the system as a whole.

The manufacturer is not liable for damages resulting from failure to follow instructions contained in this manual.

In case of doubts of the correct interpretation of the instruction, consult the manufacturer to obtain the necessary clarifications.

1.2. Composition of the manual and consultation details

This installation, use and maintenance manual is composed of chapters divided into sections, identified by a progressive numbering system at the start of each different topic. Italian is the language of the first release. The table of contents lists the chapters and sections, allowing the desired topic to be easily found.

The following symbols are used in this manual to indicate and highlight parts of text particularly important and should not be overlooked:



DANGER-ATTENTION

Denotes situations of extreme danger that if ignored could create serious risks for the health and safety of persons.



CAUTION

Denotes that suitable conduct must be followed to avoid accidents and/or causing economic damage



INFORMATION

Denotes technical information of particular importance that must not be ignored.

The descriptions and illustrations in this manual are not challenging. General D'Aspirazione reserves the right to make any modifications it deems necessary at any moment, without any obligation for prior notification

The total or partial reproduction of this document without the consent of the manufacturer is prohibited.

1.1. Manufacturer's identification

General D'Aspirazione has been operating since 1974 and is the first company in Italy in the construction of central vacuum system and has designed and manufacturers the central Monoblock.

For all requests regarding installation, use, maintenance or the supply of spare parts, customers are invited to contact only the manufacturer, whose identification data can be found on the identification plates (Figure 1).

MANUFACTURER'S data



Via del Lavoro, 8/11
47030 – San Mauro Pascoli (FC)



info@generalaspirazione.com
www.generalaspirazione.com



For all requests regarding installation, use, maintenance or the supply of spare parts, customers are invited to contact the manufacturer, whose identification data can be found on the identification plates.

1.2. Recommendations for use



In case of fire, do not attempt to extinguish it with water. Failure to observe this instruction may expose the operator to the risk of electric shock.

2. Product description

The **Patented System IWS** is a remote control system to turn on and off the central vacuum systems, consisting from a receiving unit Master (below Master Boards) and one or more transmitter slave units (below Slave boards).

The IWS Master units are of two types

| | |
|-----------|--|
| 0102386 | IWSR Master – for control units from 1 operators |
| 0102386/1 | IWSR/T Master – for control units from 2 operators |

The IWS Slave units are instead of only one type in three different colours:

| | |
|---------|------------------|
| 0102388 | IWS Slave White |
| 0102389 | IWS Slave Black |
| 0102390 | IWS Slave Silver |

2.1. How it works

Through the Brava wireless handle it sends a signal to a radio frequency (433 Mhz) to the Slave units which in turn forward it to the Master via the system of power line carrier, relying on the power supply network. The Master unit in turn sends the command to turn on to the central vacuum unit via low-voltage wiring of consent socket.

3. Installation



WARNING: the entire assemblage of equipment should be performed by qualified staff respecting the rules of art and in accordance with the various rules and regulations.



WARNING: Perform all installation sequence by removing power from the mains power supply.

3.1. Installation of the Master Unit

- Install the unit IWSR Master or IWSR / T master in close proximity to the vacuum unit
- predispose a mains power socket of 230v
- Connect the master unit to the mains supply 230 Volt.
- Connect the Master Unit to the vacuum unit through the cables of low - Cable C

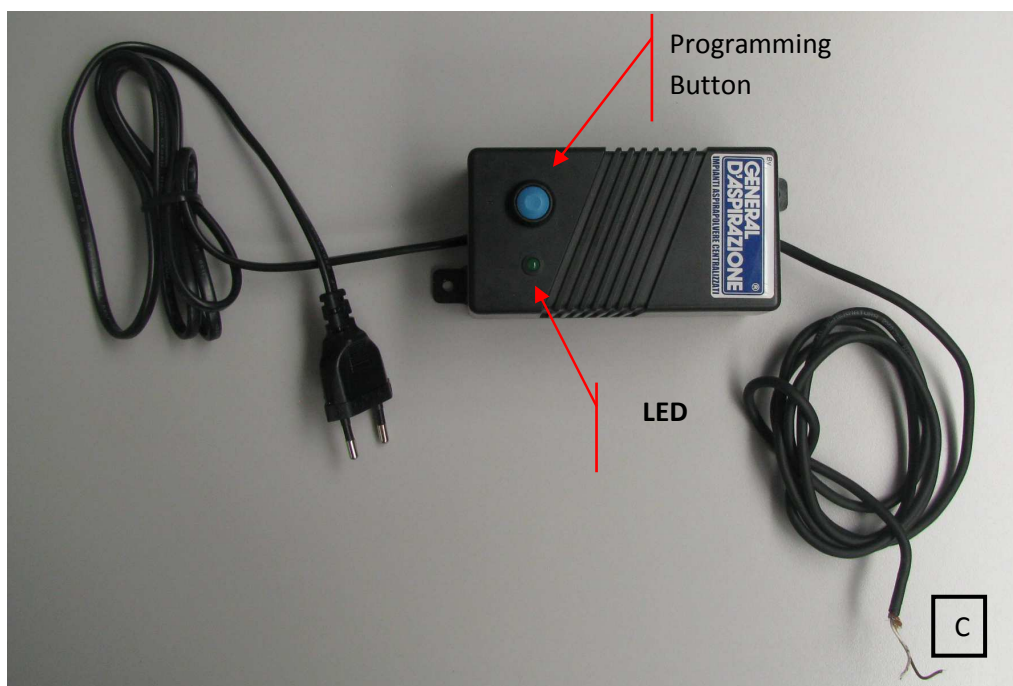

3.2. Installation of Slave Unit

- It should be predispose a number of slave boards, enough to "cover", with the transmission of the radio signal frequency, throughout the home.
- Predispose nr. 1 recessed electrical box of type 503 with its line of power supply to 230 volts, for each Slave Card.
- In the boxes of type 503 will be installed SLAVE cards as illustrated in Figure 1 and fed.



Figura 1



Important:

1. Give power supplì for MASTER and SLAVES board through the same 230V line from electrical cabinet.
2. Provide a disconnecting easy switch for power supply of SLAVE boards and one for the MASTER board

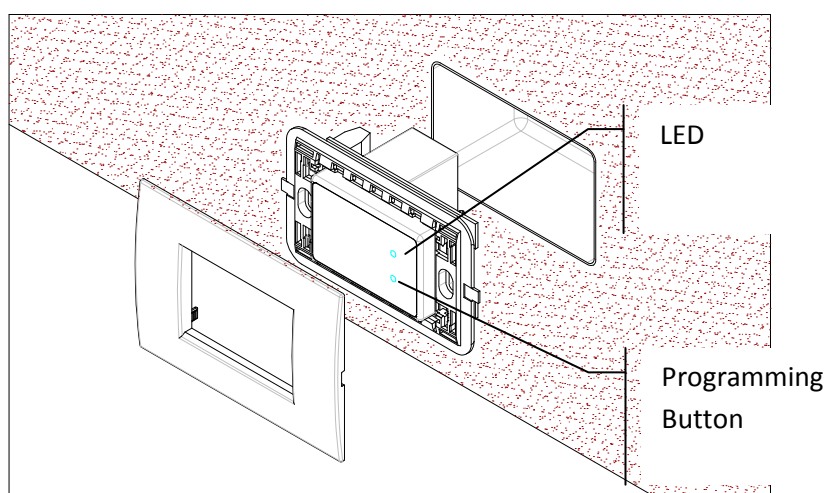
4. Configuration and Programming

Once you have completed the installation of the Master and Slave units should be given power supply taking care before the Slave units and after the Master units.

At this point you must wait about 5 minutes for the Master Unit completes the course of recognition and automatic alignment with all Slave present boards.

4.1. Programming of the Brava Wireless Handle

Completed the alignment procedure between the Master and Slave must program the Brava Wireless Handle with the Master, how to proceed:



Programming Button of
Brava Wireless Handle

- Press the programming button on the Master for about 10 seconds, until the LED begins to flash.
- Position in close proximity to a slave and hold the button on the Brava wireless handle for about 10 seconds, until the LED does not turn on, release the button and press once.
- Repeat the operation described above for all handles available.
- Completed the programming of all the handles, press once on the programming button of the Master - at this point the LED stops flashing.
- The programming is complete.

4.2. Reset of the Brava Wireless handle

To reset the Brava Wireless handle programmed with the master proceed as follows:

- Push the program button on the master for approximately 10 seconds, until the LED starts to blink
- Place close to a slave and psuh the button on the Brava Wireless handle for approximately 20 seconds until the LED goes off (after 10 seconds the LED will go on, continue for 10 more seconds until it goes off), release the button and push it once.
- Once the reset is completeted push the program button of the master once - at this point the LED stops blinking.
- The procedure of reset is completed.

5. Put out of service and disposal

When the device has terminated its cycle of use and must be decommissioned, follow these instructions to protect the environment:



The presence of this symbol on the product or on the pack indicates that the product must not be treated as normal household refuse, but must be taken to a suitable collection centre for the recycling of electrical and electronic devices.

By disposing of this product correctly, you will help to avoid potentially harmful effects for the environment and for health that might be caused by disposing of it incorrectly.

For more detailed information on recycling procedures for this product, contact your local authority, your local waste disposal agency or the dealer from which the product was purchased.



Before proceeding with decommissioning and dismantling operations of any kind whatsoever, isolate the system from the electrical power supply line.

Failure to comply with this instruction may expose the operator to the risk of accidental starting or of electric shock.

Dismantling operations must be carried out only by qualified personnel.

Industrial wastes must normally be disposed of by companies accredited for their disposal.

6. Product guarantee

The IWS system is covered by the "Legal Guarantee" required by European directives as implemented by Italian Legislative Decree 206/2005, on condition that they are used in conformity with the indications given in this Use and Maintenance Manual with regard to their intended use.



Important

The guarantee date refers to the date of the purchase invoice or receipt, and is valid for two years. **The purchase document must therefore be kept to demonstrate the validity of the guarantee.**



- It is advisable to keep packaging materials for the entire period covered by the guarantee.
- For all problems, malfunctions or defects contact your dealer, who will provide you with details of an AUTHORIZED ASSISTANCE CENTRE

7. Declaration of EC Conformity

DECLARATION OF EC CONFORMITY

INFINITY WIRELESS SYSTEM

Remote control to turn on and off the central vacuum system

Type

**MASTER IWSR
MASTER IWSR/T
SLAVE**

These industrial vacuum cleaner units are designed and manufactured in compliance with the following directives and regulations:

| | |
|-----------------------|---|
| Direttiva 2006/95/CE | Low Voltage Directive (BT) |
| Direttiva 1999/5/CE | Direttiva R&TTE |
| Direttiva 2004/108/CE | Electromagnetic Compatibility Directive (EMC) |
| Direttiva 2001/95/CE | Directive on General Product Safety |
| Direttiva 2002/95/CE | RAEE Directive - Waste Electrical and Electronic Equipment |
| Direttiva 2002/96/CE | ROHS Directive - Restriction of Hazardous Substances in Electrical Equipment |

The instruction manual indicates in particular the standards for the installation, use and maintenance of this device.

If the device is inserted as part of a system, the conformity of the overall system must be certified in the declaration issued by the operator making the final installation.

The person responsible for the drafting of the Technical Document is the Research & Development Manager at the address of the manufacturer.

GENERAL D'ASPIRAZIONE di Bianchi Claudia & C. s.a.s.

San Mauro Pascoli, 01/2019

Via Del Lavoro, 9/11 - 47030 San Mauro Pascoli (FC)

Legal Representative

Tel. 0541 931012 - Fax 0541 933763

www.generaldaspirazione.com

Claudia BIANCHI

e-mail: info@generaldaspirazione.com



Company with Certified Quality System
UNI EN ISO 9001:2015

