



since 1974

## Residential Unit Wireless INTELLIGENCE

### Mod. Wi1450

Residential unit "GDA" mod. Wi1450 for 1 user, with the following features:

- Wireless System integrated.
- All made in plastic material ABS of high quality.
- Class II of protection "double insulation".
- Solid and liquid protection IP40 for the installation also in outdoor environment.
- Electronic system SOFT START that allows the modulated start of the motor.
- Integrated silencer inside the unit.
- Total reversible of inlet and outlet air, placed on both side, or not, of the unit.
- Dust container system with a single front handle.
- Dust bag with cardboard sack tend.
- Fast unlook of the filter with filter lock ring.
- Internal protection against the shock of solid materials to the filter.
- Self-locking wall fixing system with frontal insertion on a special wall bracket and release by pressing two side wings.
- User interface to monitor the correct functioning of the system and the right timing for every maintenance intervention.
- System of protection against unintentional switch on.
- Stand-by consumption lower than 1 Watt (European Directive 2005/32/CE).
- Spare filter.



Data Label			
Power Supply	230 V		
Max Absorbition	7,3 A		
Frequency	50/60 Hz		
Motor Power	1450 W		
Performance			
Socket Supply dc	5 V		
Air Flow	179 m <sup>3</sup> /h		
Depression	3950 mmH <sub>2</sub> O		
Vacuum Power	66 dB (A)		
Technical data			
Intelligent electronics	YES		
Stand-by consumption	1 Watt		
Dust bag capacity	18 litres		
Ø inlet/outlet	50 mm		
Self cleaning filter	NO		
Dimension			
Diameter	300 mm		
High	1041 mm		
A "minimun"	40 mm		
B	695 mm	D	210 mm
C	104 mm	E	370 mm

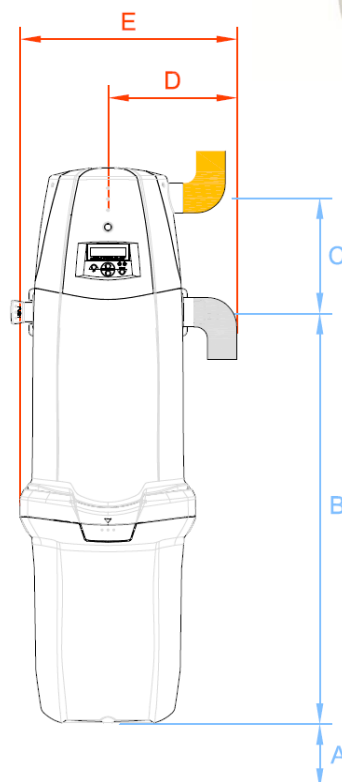

General D'Aspirazione – San Mauro Pascoli FC - Italy

[www.generaldaspirazione.com](http://www.generaldaspirazione.com)