



since 1974

## Residential Unit Wireless STANDARD

### Mod. WS1250

Residential unit "GDA" mod. WS 1250 for 1 user, with the following features:

- All made in plastic material ABS of high quality.
- Class II of protection "double insulation".
- Solid and liquid protection IP55 for the installation also in outdoor environment.
- Electronic system SOFT START that allows the modulated start of the motor.
- Integrated silencer inside the unit.
- Total reversability of inlet and outlet air, placed on both side, or not, of the unit.
- Dust container system with a single front handle.
- Dust bag with cardboard bag tend.
- Fast unlook of the filter with filter lock ring.
- Internal protection against the shock of solid materials to the filter.
- Self-locking wall fixing system with frontal insertion on a special wall bracket and release by pressing two side wings.
- **Integrated wireless system receiver**



Data Label			
Power Supply	230 V		
Max Absorbition	6,4 A		
Frequency	50/60 Hz		
Motor Power	1250 W		
Performance			
Socket Supply dc	5 V		
Air Flow	230 m <sup>3</sup> /h		
Depression	2830 mmH <sub>2</sub> O		
Vacuum Power	61 dB (A)		
Technical data			
Intelligent electronics	NO		
Stand-by consumption	4,5 Watt		
Dust bag capacity	18 litres		
Ø inlet/outlet	50 mm		
Self cleaning filter	NO		
Dimension			
Diameter	300 mm		
High	940 mm		
A "minimun"	40 mm		
B	695 mm	D	210 mm
C	194 mm	E	370 mm

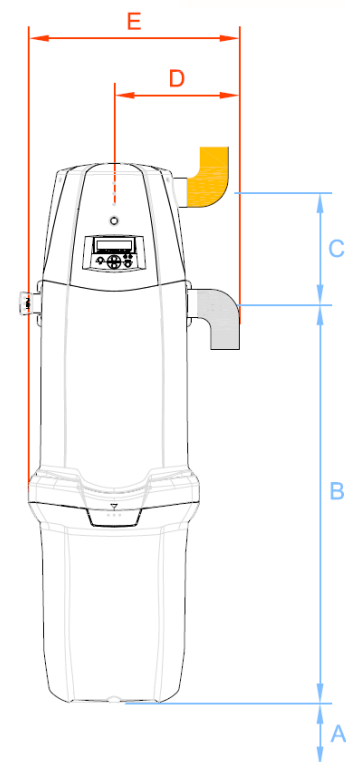

General D'Aspirazione – San Mauro Pascoli FC - Italy

[www.generaldaspirazione.com](http://www.generaldaspirazione.com)