

Installation, Use and Maintenance Manual

rev. 22-03



**GENERAL
D'ASPIRAZIONE**®
IMPIANTI ASPIRAPOLVERE CENTRALIZZATI

MADE IN ITALY

1.	General safety information	2
1.1.	Purpose of this manual	2
1.2.	Composition of the manual and consultation details	2
1.3.	General safety precautions	3
1.4.	Safety and hazard signals	4
1.5.	Identification of the manufacturer	4
1.6.	Technical documentation supplied with the Commercial unit	6
1.7.	Serial equipment included in the Commercial unit	6
1.8.	Correct and improper uses	6
1.9.	Recommendations for use	6
2.	Technical features Commercial unit	8
2.1.	Description of the Commercial Unit	8
2.2.	Models of reference and features of centrals with inverter	9
2.3.	Suction turbines	10
2.4.	Cyclonic dust collection separator	10
2.5.	Electrical board of safety control	12
3.	Handling and unpacking	13
4.	Installation of the Commercial unit	14
4.1.	Choosing the installation area	14
4.2.	Installation of the Commercial unit	14
4.3.	Mechanical collection	15
4.4.	Electrical connection	16
4.4.1.	Connection of the electrical board	16
4.4.2.	Connection of the suction turbine	17
4.4.3.	Connection of the relay (OPTIONAL)	17
5.	Use and function of the Commercial unit	18
5.1.	First switch-on	18
5.2.	Mode of function	18
5.3.	Check of the system	18
5.4.	Use of the inverter control board	19
5.5.	Modification of the setpoint of the central	21
5.6.	Ordinary maintenance alarm	21
5.7.	Function of the self-cleaning system	22
5.8.	Setting of the language user interface	23
5.9.	Definition of principles of function	23
5.10.	List of preferred parameters	24
6.	Maintenance	25
6.1.	Ordinary maintenance	25
6.2.	Replacement of the dust bag	25
6.3.	Replacement of the filter cartridge (Filter)	26
6.4.	Cleaning of the filter cartridge (Filter)	27
6.5.	Extraordinary maintenance	28
7.	Spare parts	28
8.	Inconveniences; causes and remedies	30
9.	Live end procedures and final disposal	33
10.	Warranty on the product	34
11.	Declaration of CE conformity	36
12.	Maintenance records	37

1. General safety information



Read this manual carefully before starting operations of movement, unpacking, installation, use, maintenance and decommissioning of the Commercial vacuum unit.

A copy of this manual is available on the website:

www.generaldaspirazione.com

1.1. Purpose of this manual

This installation, use and maintenance manual is an integral and essential part of the Commercial vacuum unit.

Its purpose is to provide all necessary information to allow the installer to install the system in full compliance with the manufacturer's specifications, the user to operate the system in the safest and most independent way, and maintenance technicians carrying out programmed maintenance operations to ensure the correct operation of machinery and the system as a whole.

The manufacturer declines all liability for damage deriving from failure to observe the instructions given in this manual. In case of doubts on the correct interpretation of instructions, contact the manufacturer to receive the necessary explanations.

1.2. Composition of the manual and consultation details

This installation, use and maintenance manual is composed of chapters divided into sections, identified by a progressive numbering system at the start of each different topic. Italian is the language of the first release.

The table of contents lists the chapters and sections, allowing the desired topic to be easily found.

The following symbols are used in this manual to indicate and highlight particularly important parts of the manual that must not be ignored:



DANGER - ATTENTION

Denotes situations of extreme danger that if ignored could create serious risks for the health and safety of persons.



CAUTION

Denotes that suitable conduct must be followed to avoid accidents and/or causing economic damage.



INFORMATION

Denotes technical information of particular importance that must not be ignored.

The descriptions and illustrations provided in this manual are not binding. General D'Aspirazione reserves the right to make any modifications it deems necessary at any moment, without any obligation for prior notification.

The total or partial reproduction of this document without the consent of the manufacturer is prohibited.

1.3. General safety precautions

The purpose of this information is to make persons interacting with the system aware of all possible conditions of danger, and thereby to avoid injuries either to themselves or to others.

Design for safety

During the design and construction phase, the manufacturer dedicated particular attention to aspects that may cause risks for the safety or health of persons using the system.

In addition to complying with applicable laws, the manufacturer followed all rules for Good Manufacturing Practices.

Nevertheless, some parts of the system could cause risks that are not immediately evident. It is therefore advisable to take particular care during use of the system and during routine maintenance operations.

Safety during use

Before starting to use the system in any way whatsoever, the instructions given in this manual supplied must be read carefully and completely, together with the indications provided directly on the system with safety warning symbols.

Do not tamper with, bypass or remove the safety devices installed on the system.

Failure to observe these instructions may cause risks for the safety or health of persons.

Safety during maintenance

Personnel carrying out any kind of routine maintenance on the system during its entire lifespan must possess specific technical skills, special capacities and acquired experience recognized in the sector in question.

The absence of these requisites may cause risks for the safety or health of persons.

During normal use or during any kind of operations on the system, the safety distances around it must be maintained in order to avoid causing risks for the safety or health of persons.

For some operations the help of one or more assistants may be necessary.

1.4. Safety and hazard signals

The following symbols are used in this manual and on the system to draw attention to procedures that persons interacting with the system must scrupulously respect to protect their own safety and to prevent damage to the system.



ELECTRICITY LIFE HAZARD



HIGH TEMPERATURE HAZARD



CRUSHING HAZARD



PROHIBITED TO EXTINGUISH FIRES WITH WATER



**IT IS PROHIBITED TO REMOVE THE PROTECTION AND SECURITY DEVICES
DON'T USE THE CENTRAL WITHOUT THE PROTECTIONS**



PROHIBITED FOR PERSONS NOT SUITABLY TRAINED TO USE THE SYSTEM



**COMPULSORY TO WEAR PROTECTIVE MASK AGAINST INHALATION OF DUST AND
HARMFUL SUBSTANCES**



**COMPULSORY TO WEAR PROTECTIVE GLOVES AGAINST CONTACT WITH DUST AND
HARMFUL SUBSTANCES**



COMPULSORY TO WEAR SAFETY FOOTWEAR



COMPULSORY TO WEAR PROTECTIVE GLOVES WHILE MOVING GOODS

1.5. Identification of the manufacturer

This Commercial vacuum unit was designed and produced General D'Aspirazione, founded in 1974 and Italy's leader in the manufacture of centralized vacuum cleaner systems.

For all requests regarding installation, use, maintenance or the supply of spare parts, customers are invited to contact only the manufacturer, whose identification data can be found on the identification plates (Figure 1).

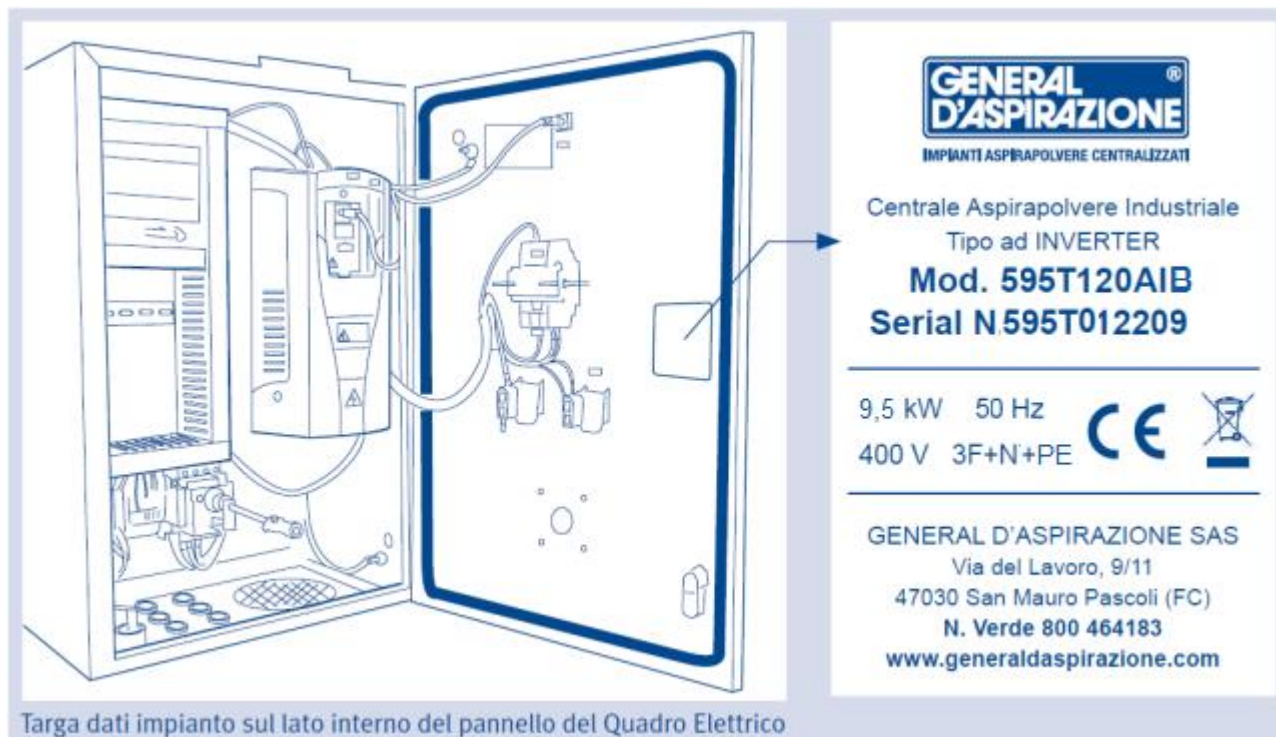

Figure 1

The identification plate is located on the right-hand side of the vacuum unit.

For all requests for technical assistance, in addition to details of the problem encountered, customers are asked to inform the manufacturer of all system information given on the identification plate, as follows:

- system model
- serial number

MANUFACTURER information



Via del Lavoro, 9/11
47030 – San Mauro Pascoli (FC)



info@generaldaspirazione.com
www.generaldaspirazione.com



For all requests regarding installation, use, maintenance or the supply of spare parts, customers are invited to contact the manufacturer, whose identification data can be found on the identification plates.

1.6. Technical documentation supplied with the Commercial unit

1. Use and Maintenance Manual for Commercial vacuum unit
2. Scheme of the electric connection
3. Board of mechanical monitoring with list of fittings
4. Technical manual inverter
5. Technical manual compressor (where present)

1.7. Serial equipment included in the Commercial unit

The serial equipment :

- n.2 rubber couplings with ties for the connection of the central to the system
- n.1 dust bag
- n. 1 protective facemask and gloves

1.8. Correct and improper uses



ATTENTION: Uses other than those indicated are not permitted.

No modifications or adaptations of the vacuum unit are permitted.

Any use whatsoever other than the use for which the product has been designed represents improper use that may damage the vacuum unit and constitute a serious hazard for the user.

General D'Aspirazione Commercial vacuum units are designed and constructed solely to vacuum dust of a domestic type into a central unit inside civil buildings.

The Commercial system must be used vacuum only dust and objects of small dimensions.

For specific needs contact the General D'Aspirazione technical office. The manufacturer declines all and any liability for damage to the system or to other things and/or injuries to persons caused by improper use of the system.

1.9. Recommendations for use



In case of fire, do not attempt to extinguish it with water. Failure to observe this instruction may expose the operator to the risk of electric shock.



This system is designed to be installed by adequately trained and instructed personnel.



This unit can be used by children aged from 8 years and up and persons with reduced physical capacity, sensory or mental or lack of experience and knowledge if they received supervision or instruction concerning use of the appliance safely and understood the risks involved.

Children should not play with the appliance. The cleaning and maintenance performed by the user should not be made by children without supervision.

Vacuum units are destined for use in residential buildings. Their use during building work may cause serious deterioration that is not covered by the guarantee.

- Do not suck up plaster, cement or rubble. These operations can be performed using the liquid cleaner accessory (see brochure on available accessories).

- Do not use the machine for inappropriate purposes. Do not suck up glowing embers, cigarette ends still lit, inflammable products or materials that could cause flames in the dust collection container, materials with a high risk of explosions or materials that individually are inert but that when mixed together may cause dangerous chemical reactions.
- It is prohibited to use vacuum units for unintended purposes in industrial facilities in the presence of values of temperatures, pressure and humidity in excess of those of normal workplaces.
- Do not suck up liquids, ashes in fireplaces, large quantities of flour, printer toner, building site dust, fine powder, cement or plaster.
- Always disconnect the power supply at the electrical panel:
 - during installation;
 - if maintenance or repair operations are necessary;
 - if the system is not to be used for a long period.
- Do not under any circumstances whatsoever work on the unit while it is operating.
- Wear protective gloves and a facemask for all maintenance work (emptying of dust container, cleaning or replacement of filter).
- Use only original spare parts.
- Do not use the vacuum unit without the filter.
- After all maintenance operations ensure that the filter has been replaced and correctly tightened.
- Do not obstruct air inlets or outlets.
- Do not allow parts of the body to come into contact with accessories of the vacuum unit, and never direct the suction mouthpiece toward persons or animals.
- Ask the installer carrying out the final system trial to certify that the system has been correctly installed.



IMPORTANT

Ask the installer carrying out the final system trial and regulation to certify that the system has been correctly installed.

2. Commercial vacuum units – Technical Characteristics

2.1. Description of the Commercial Vacuum Units

With the name of commercial vacuum unit there are intended all the systems that are realized in environments different from private residences, such as hotels, cinemas, theatres, gambling halls, congress halls, offices, industries, etc.

The commercial vacuum unit uses a turbine with an electric motor to generate air depression upon ignition. The rotative speed of the turbine is regulated by an inverter. According to the set depression, the inverter regulates the frequency of rotation in based on the depression detected by a pressure transducer.

The aspirated air is conveyed into the cyclonic separator, where the dust falls into the collecting container, while the particles, that climb up to the superior part of the separator, are kept down by the filtering cartridge. The filtered air is expelled outside through the exhaust of the turbine.

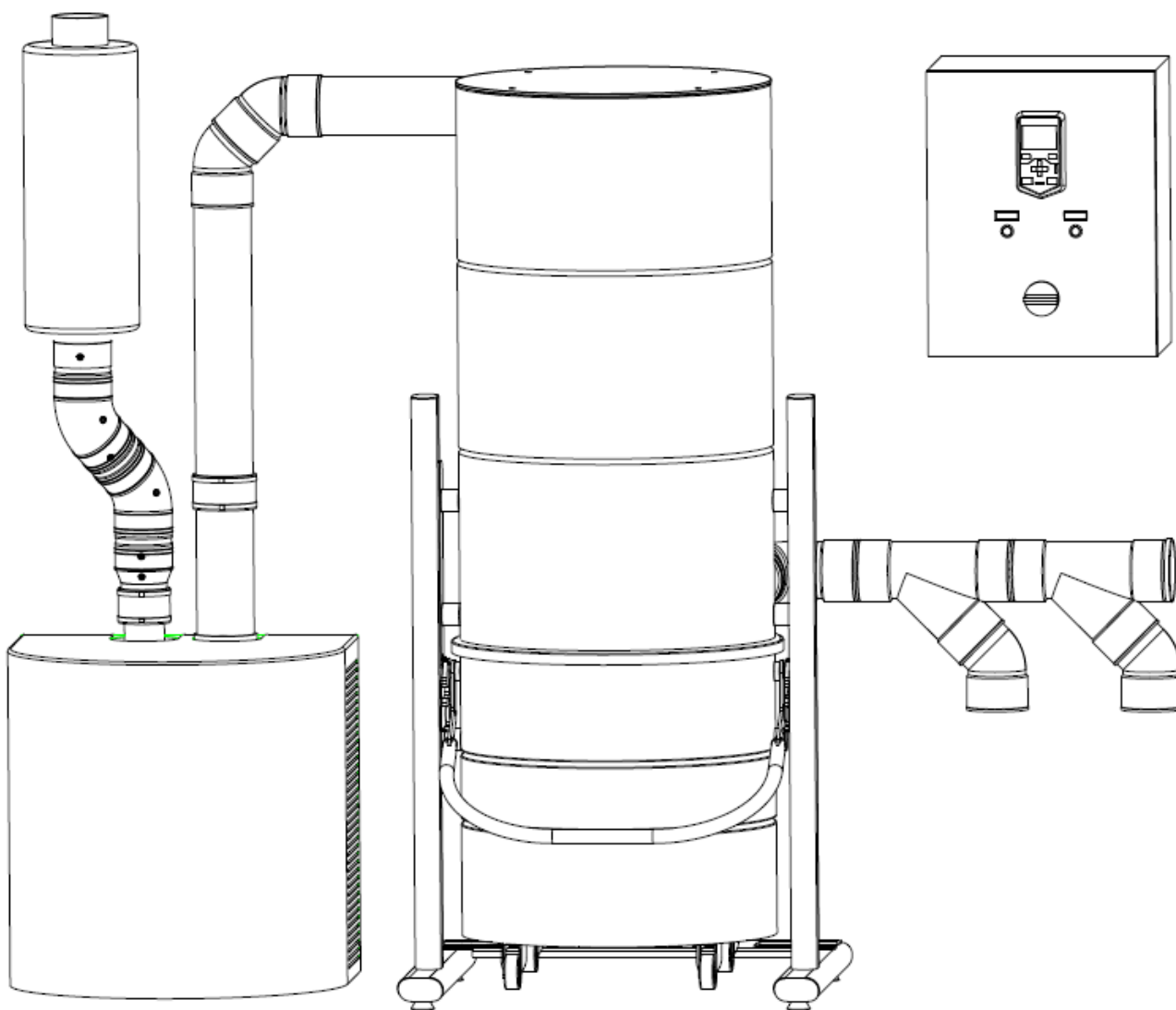

2.2. Models and characteristics of Commercial Vacuum Units with inverter

	230T120AIB	350T120AIB	469T120AIB	595T120AIB	713T120AIB	1020T120AIB
Number of users	2	3	4	5	6/7	10
Work area (m2)	1000 – 2000	2000 - 3000	3000 - 4000	4000 – 5000	5000 – 7000	7000 – 10000
Turbine						
Max Frequency (Hz)	≤ 86	≤ 86	≤ 86	≤ 86	≤ 86	≤ 86
Power Supply (V)	400	400	400	400	400	400
Max motor power (kW)	3,6	5,0	6,9	9,5	13,0	20,5
Max air capacity (m3/h)	480	780	900	900	1150	1850
Working depression (mbar)	160	160	160	160	160	160
Absorption (A)	9,7	12	15,6	22	27,5	44
Noise (dB)	< 69	< 69,5	< 72	< 74	< 74,5	< 74,5
Weight (Kg)	26	36	43	136	145	145x2
Dim. Input/output turbine (")	2"	2"	2"	2 ½"	2 ½"	2 ½"
Inverter	SI	SI	SI	SI	SI	SI
Soundproof box	SI	SI	SI	SI	SI	SI
Silencer	SI	SI	SI	SI	SI	SI
Cyclonic Separator						
Dust container (l)	120	120	120	120	120	120
Ø (cm)	55	55	55	55	55	55
Height (cm)	161	161	161	161	161	161
Width (cm)	74	74	74	74	74	74
Depth (cm)	79	79	79	79	79	79
Weight (Kg)	100	100	100	100	100	100
Self-cleaning	SI	SI	SI	SI	SI	SI
Ø Input/output (mm)	100	100	100	100	100	100

2.3. Suction Turbines

The suction turbines are equipped with a new system with turning inclined blades that allow elevated performance with superior depression and airflow.

Based on the needs of installation there are different turbines available.

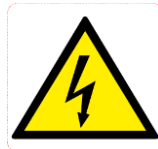
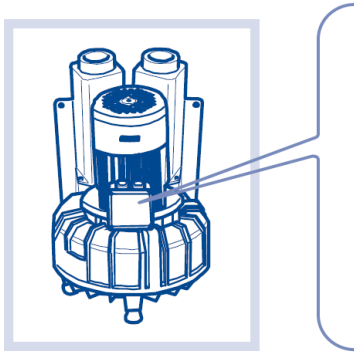

ELECTRICITY LIVE HAZARD





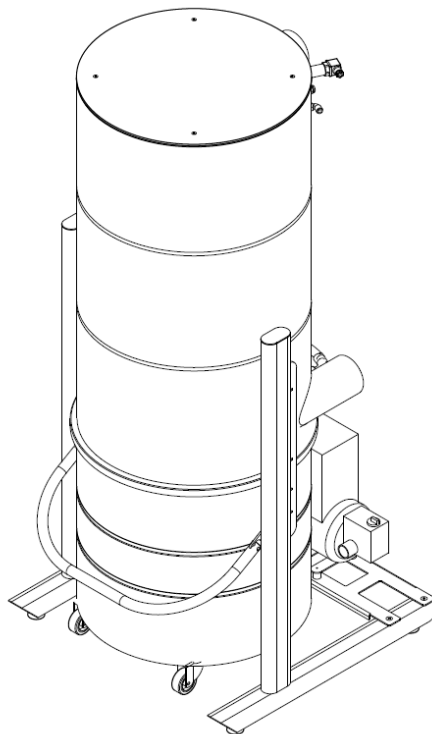

HIGH TEMPERATURE HAZARD

2.4. Cyclonic separator for dust collection

The separator is equipped with a self-cleaning system of the filter through a compressor placed on the base frame and an air tank with integrated electro valve.

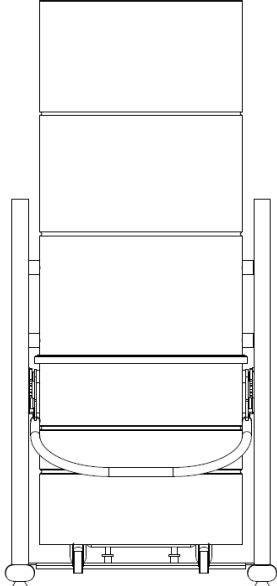

The volumes of the separators are reported in the table of **chapter 2.2**

<p>Applicazione adesivi di prescrizione sul montante sinistro del Separatore:</p> <ul style="list-style-type: none"> PRESCRIZIONE DI LEGGERE IL MANUALE PRESCRIZIONE USO MASCHERINA LEGGERA PRESCRIZIONE USO GUANTI LEGGERI		<p>Applicazione adesivi di sicurezza sul montante destro del Separatore:</p> <ul style="list-style-type: none"> PERICOLO GENERICO PERICOLO DI SCHIACCIAMENTO
--	---	--

2.5. Electrical control and safety switchboard

The electrical control and safety board with inverter with self-cleaning is equipped as follows:

- A. General ON/OFF switch
- B. Manual self-cleaning button
- C. "Check" button to reset standard maintenance
- D. Control panel of the inverter

The electrical board is equipped with the following safety device:

- General magnetothermic switch with contact block

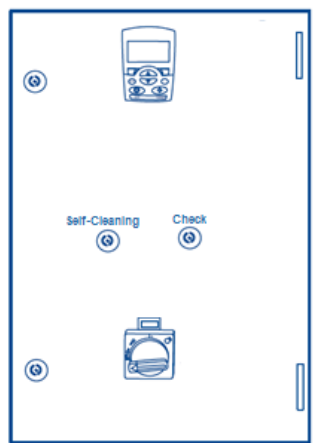
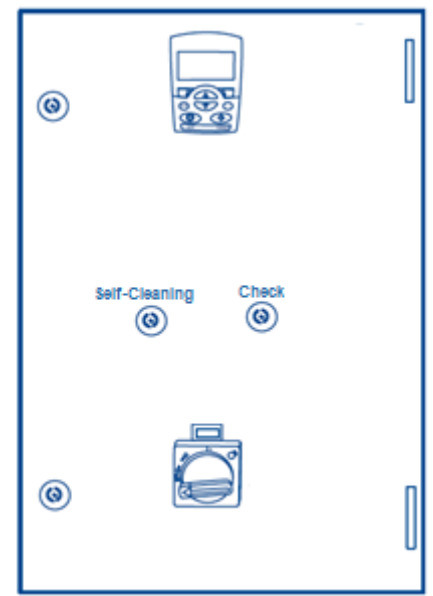

Applicazione adesivi di sicurezza sul Quadro Elettrico:



DIVIETO DI SPEGNERE INCENDIO CON ACQUA



PERICOLO TENSIONE ELETTRICA



**DIVIETO DI MANOVRA A PERSONE
NON ADEGUATAMENTE FORMATE E ADDESTRATE**

3. Movement and unpacking

The Commercial vacuum unit is shipped fixed to a europallet inside a cardboard carton to protect it during transport and delivery.

It is advisable not to remove the packaging until the moment of installation, to avoid possible damage.



ATTENTION

Suitable lifting equipment must be used when moving the vacuum unit, and particular care must be taken to correctly balance loads.



CAUTION

Never turn a vacuum unit that is still packed upside down.

Do not use box cutters to remove packaging materials.

The manufacturer declines all and any liability for damage caused by the incorrect opening of packaging materials.



ATTENTION

During movement operations use appropriate items of personal protection equipment.

Failure to use appropriate items of personal protection equipment during movement and unpacking may expose the operator to the risk of crushing of the feet due to loss of stability.



Failure to wear safety gloves prevents a safe grip during movement operations with the risk of accidental falls.

On delivery it is necessary to immediately check the materials supplied for correctness and lack of damage with the transporter to avoid claims for damage not attributable to shipping.

If damage to the equipment is found, it is necessary to proceed as follows:

- note the type of damage on the transport document (transporter's copy);
- send the transporter a registered letter requesting compensation for the damage within two days;
- contact the Assistance Service of the manufacturer for any necessary replacement parts.



ATTENTION

The support surface must not have a slope of more than 8%, to avoid the risk of overturning due to loss of stability.



IMPORTANT

Packaging materials must be kept for the entire period covered by the guarantee.

4. Installation of the Commercial Vacuum Unit

4.1. Choice of installation position for the Commercial vacuum unit

The choice of installation position must be based on these criteria:

- The commercial vacuum unit must be installed indoors in well-ventilated rooms, preferably in a service room on the lowest floor of the building, like a garage or technical utilities room, or in external locations, provided that the vacuum unit is always protected against bad weather.
- The selected position must have a clear and well-lit space around the main vacuum unit, so as to facilitate maintenance and repair operations.
- The main vacuum unit **must not be installed** in rooms where:
 - there is a source of heat in the immediate vicinity
 - ambient temperature can reach values lower than 5°C and above 35°C
 - humidity is very high or flooding may occur
 - flammable or explosive products are present
- Its location must be able to realize the pipe for the exhaust

4.2. Installation of the Commercial vacuum unit

The industrial centrals are composed of three principal elements:

- Aspirating turbine
- Dust separator
- Electrical switchboard for control and safety



This system is designed to be installed by adequately trained and instructed personnel.



Before the operation of installation isolate the central from the power supply. Not doing so exposes the operator to the risk of electric shock.



The entire system must be installed by qualified personnel in full compliance with standards of workmanship and with applicable standards and regulations.



During installation operations use appropriate items of personal protection equipment.



Failure to use appropriate items of personal protection equipment during movement and unpacking may expose the operator to the risk of crushing of the feet due to loss of stability.

Failure to wear safety gloves prevents a safe grip during movement operations with the risk of accidental falls.



It is strictly forbidden to remove the protection and safety devices. Don't use the central without the protections.

Each unit is accompanied by a connection scheme that has to be followed in order to do a perfect installation. As an example the mechanical connection scheme of the central model 469T120AIB is reported. Each central comes with its breakdown of the respective assembly. In the scheme taken as example there is the breakdown of the components of connection between the separator and the turbine, along with the system, and the components to remote externally the exhaust of the turbine. Once completed the mechanical connection proceed with the wiring of the electric system of the unit.

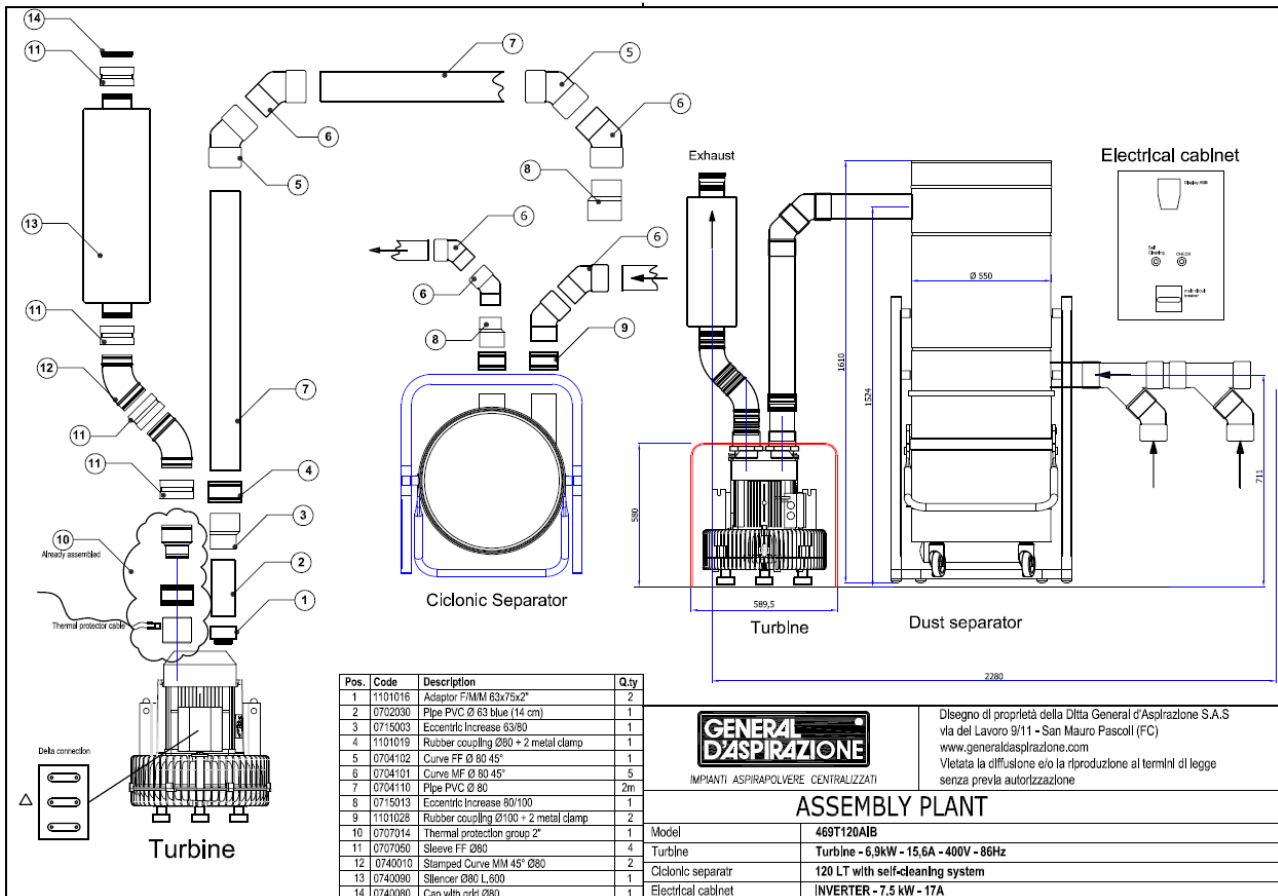

4.3. Mechanical Connection

For the mechanical connection proceed as follows:

1. Dispose the three principal elements (turbine, separator and electric board) according to the enclosed scheme.
2. Connect the aspiration of the separator with the distribution piping network. For this purpose, use the rubber sleeves. The function is indicated in the lower left of the display.
3. Connect the exit of the dust separator with the aspiration of the turbine. For this purpose, use the rubber sleeves and the ties supplied with the central.
4. Remote externally the exhaust of the air of the turbine.



IMPORTANT

- Use metal tubing for the expulsion of the air
- Consult the technical office for support regarding the correct dimensions of the air expulsion tubing

4.4. Electrical Connection

To complete the electric connection of the systems with inverter you need to connect all components, as per scheme enclosed inside the board.



Complete the installation without connecting the system to the electrical net



The electrical connection has to be carried out exclusively by qualified personnel as per electrical scheme enclosed to the system and in conformity with the actual norms.

4.4.1. Connection to the electrical board of control and safety

Once completed the mechanical connection you need to wire the electric board. The following is an example of an electrical scheme of an industrial central.

Every industrial central is supplied with a specific electrical scheme that you find inside the electrical switchboard:

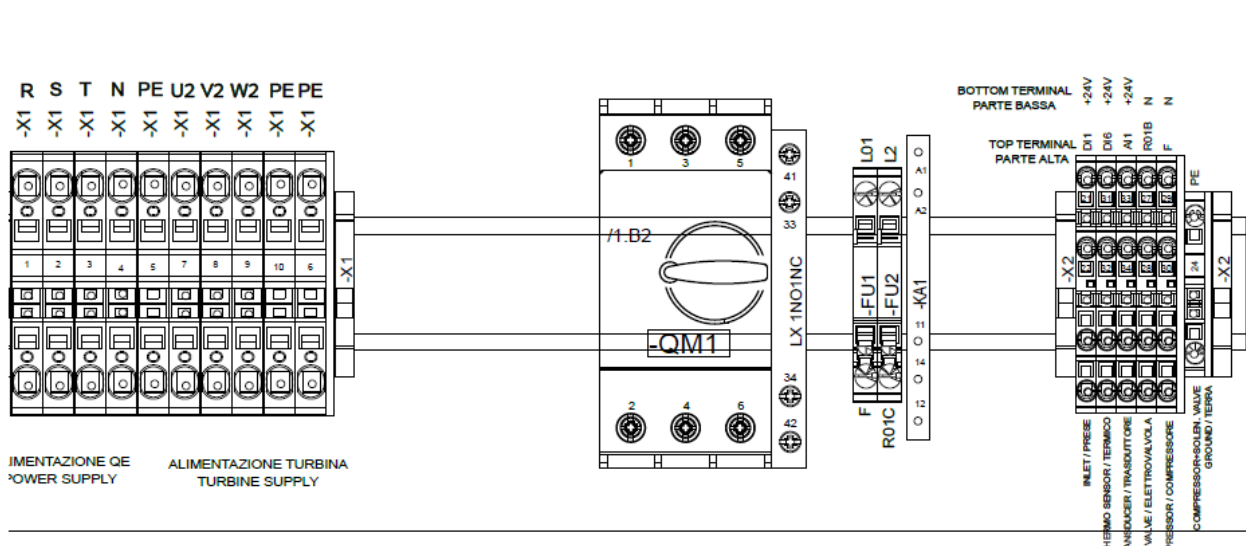

If the turbine turns in contrary sense to the aspiration it is sufficient to invert its phase inside the electrical board to invert rotation.

The correct section of the electric wires varies based on the type of vacuum central. The maximum absorptions of each model of central are reported in **chapter 2.2**



Grade of electric protection - Class 1 – system with fundamental electric insulation. Has to be connected to the earthing circuit of the general electric system



Provide differential electrical on top from 0.3A Class B

4.4.2. Electrical connection aspirating turbine

The connection of the clamos under the cap of the aspirating turbine can be done with star or triangle connection.

Therefore it is necessary to fully respect one of the following schemes attached to the turbine.

In case of any doubt on the type of connection contact the technical office.

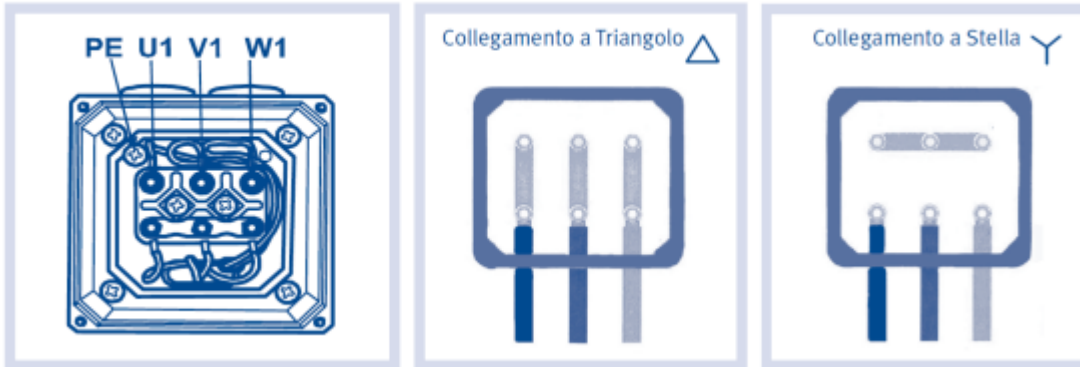

The electrical connection is already predisposed in the correct mode by the manufacturer and there is a label on the cap of the turbine with the correct connection to be done based on the specific type of vacuum central.

The models indicated in table **chapter 2.2** all have an electrical connection in triangle.

The correct section of the wires varies according to the type of vacuum central. The maximum absorption of each model of vacuum central is reported in **chapter 2.2**

4.4.3. Electric connection relay module (OPTIONAL)

If the central includes the optional relay it is possible to do the wiring to the module as per attached scheme. For all the relay outlets it is possible to choose the contact normally open or normally closed.

Specifics of the relay exits

Maximum tension: 230Vac / 30 Vdc Maximum current: 2°

	COM		Relay "3" → Motore ON
	NC		
	NO		
	COM		Relay "4" → Generic fault
NC			
NO			
COM		Relay "5" → Container control	
NC			
NO			
COM		Relay "6" → Filter control	
NC			
NO			

5. Use and operation of the Commercial Vacuum Unit

5.1. First switch-on



The completed system must be started for the first time only by an authorized technician, who will issue a Final System Test Certificate.

After the safety and correct operation of the system have been checked, it is essential to ensure that all persons who will be involved in operation of the system are suitably trained and made aware of all the information provided in this manual. In particular, they must be informed of the risks involved in operation of the system and of the precautions to be taken to reduce risks during operation to a minimum.

5.2. Operations instructions

Switching on

- Insert the plug of the central into the in-wall electric socket with the correct dimensions.
- Place the general switch of the electrical board on ON (>Figure 3, page 13).
- Insert the flexible operating hose into any suction point of the system to start the vacuum unit. For circuits with IWS system push the button on the Brava Wireless handle.
- Make sure that the control panel is in REMOTE mode, visible on the panel

Switching off

- close all the suction points of the system and remove the flexible operating hose. The vacuum unit will turn off automatically.
- It is possible to switch off the central with the LOC/REM button on the control panel, and, when the LOCAL mode is active, by pushing the STOP button.

The central can also be switched off by putting the switch on the electrical board in OFF or removing the pentapolar plug from the socket.



It is advisable to keep the power supply to the vacuum unit turned on, allowing it to be restarted for subsequent uses. If instead the system will not be used for a long period of time, it is advisable to move the main switch on the control panel to the **0 position**.



**IT IS FORBIDDEN TO REMOVE THE PROTECTION AND SAFETY DEVICES.
DO NOT USE THE CENTRAL UNIT WITHOUT THE PROTECTIONS.**

5.3. Final system test

After the industrial vacuum unit has been started for the first time, the system can be checked. It must have no leaks.

To check that the system has no leaks, first inspect the suction points (with the turbine operating) and check that they are airtight with the cover closed.

Finally check the airtightness of the vacuum pipes, using a VACUUM METER to measure the low-pressure value at one suction point on every operation line of the system, and comparing the value obtained with the values measured on the vacuum unit when this is disconnected from the system.

As an alternative, the frequency of operation (with the suction points closed) can be compared with the frequencies indicated on the Final Trial Certificate for the vacuum unit supplied by General D'Aspirazione.

5.4. Operation of the inverter on the control panel

On commercial vacuum units, the inverter controls operation of the suction turbine.

A transducer that measures operating suction pressure is connected to the inverter. Using the signals received, the inverter maintains the pre-set operating parameters constant, increasing or reducing the rotation frequency of the turbine as the conditions of use vary or according to the number of suction hoses connected.

All parameters are optimized by the manufacturer and The programmed depression value is at -160mBar.

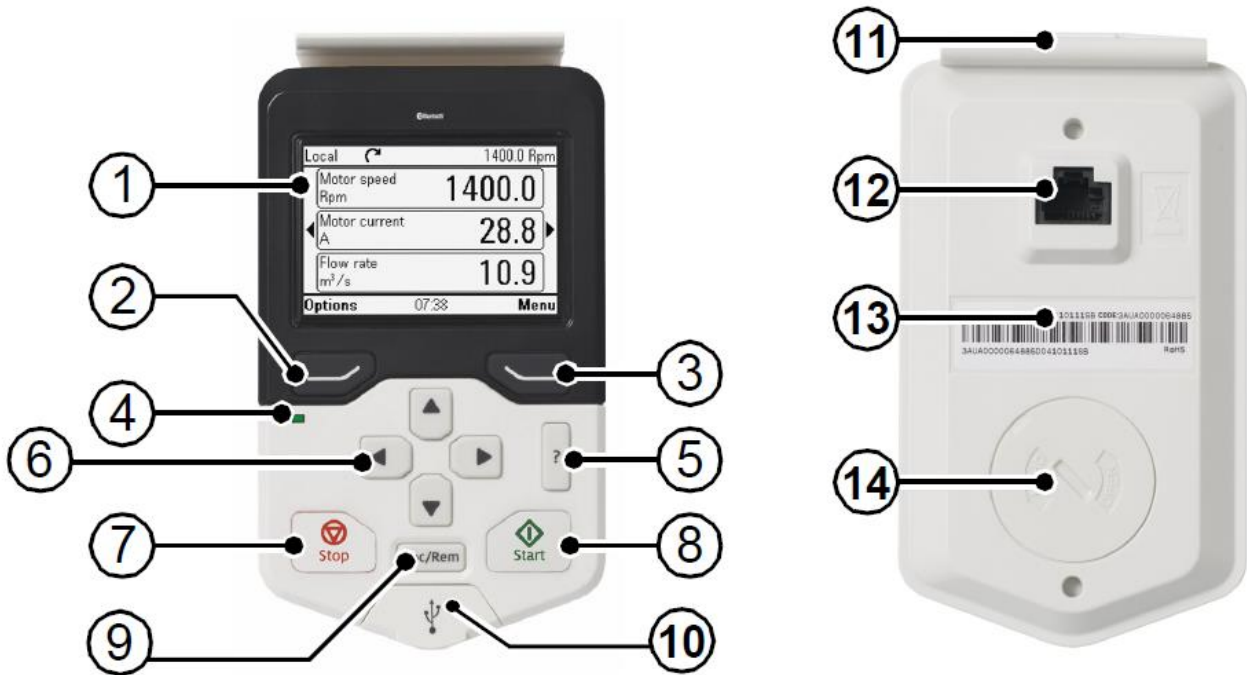

1	Display	8	Start
2	Left function Key	9	Local/remote operation
3	Right function Key	10	USB Connector
4	Status Led	11	Clip lock panel
5	Help	12	RJ-45 Connector
6	Directional Case	13	Panel data label
7	Stop	14	Battery cover

The user interface panel easily permits to see the parameters and configurations of each central. With the directional keypads the visualisation pages can be scrolled and give the following information:

Pagine	Displayed parameters	
Pag. 1	<p>Operating frequency Vacuum turbine operating frequency In stand-by the value is 0Hz</p> <p>Real vacuum: Real vacuum value in the system. The actual vacuum value will tend to become stable at the preset vacuum value (set point).</p>	<p>Remote ACS480 -160.0 mbar</p> <p>Output frequency 43.67 Hz 0.00 86.00</p> <p>Real Vacuum 0.0 mbar -250.0 0.0</p> <p>Options 08:31 Menu</p>
Pag. 2	<p>Instantaneous consumption: Indicates the instantaneous current consumption during use of the vacuum system. In stand-by the value is 0A</p> <p>Instantaneous power: Indicates the instantaneous power in kW during use of the vacuum system. In stand-by the value is 0kW</p>	<p>Local ACS480 43.6 Hz</p> <p>Motor current 8.8 A 0.0 20.0</p> <p>Output power 1.2 kW 0.0 10.0</p> <p>Options 08:32 Menu</p>
Pag. 3	<p>Actual daily consumption kWh: Indicates the daily consumption in kWh on today's date.</p> <p>Previous day's consumption kWh: Indicates the daily consumption in kWh on the previous day.</p>	<p>Remote ACS480 -160.0 mbar</p> <p>Hours run</p> <p>1.6 h 0.0 100000.0</p> <p>Options 08:32 Menu</p>
Pag. 4	<p>Relay status: Indicates the instantaneous status of the relays</p> <p>Digital input Status: Indicates the instantaneous status of the digital inputs.</p>	<p>Remote ACS480 -160.0 mbar</p> <p>RO status 0000</p> <p>DI status 0010 0000</p> <p>Options 08:32 Menu</p>
Pag. 5	<p>Operating hours Indicates the actual operating hours of the vacuum turbine.</p>	<p>Remote ACS480 -160.0 mbar</p> <p>Hours run</p> <p>1.6 h 0.0 100000.0</p> <p>Options 08:32 Menu</p>

5.5. Changing the vacuum system setpoint

In all the vacuum systems the setpoint is preset at -160 mbar. This value indicates the constant operating vacuum that the vacuum system should reach. The inverter will then adjust the turbine frequency so that the actual vacuum value reaches the preset value, called the setpoint. To change the setpoint, proceed as follows:

1. Enter the menu section using the function key (⏪); then, using the arrow keys, enter the parameters group.
2. Select the "FAVOURITES" parameters list.
3. Enter parameter 40.21, change the vacuum value using the Appropriate (N.B. it is not possible to set a value lower than -140 mbar or higher than -200mbar)
4. Return to the HOME screen using the BACK/EXIT key.

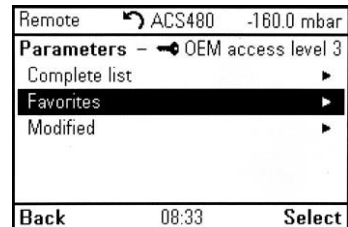
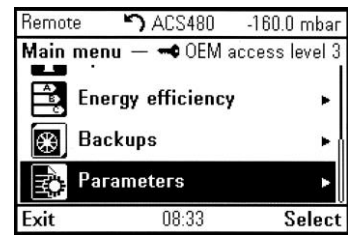

5.6. Routine maintenance signalling

All models are equipped with a warning system that notifies the operator of routine maintenance checks to be carried out.

CHECK DUST CONTAINER:

The inverter is equipped with a factory preset timer that trips the "Check Container" alarm after the set number of hours.

The preset timer can be changed using parameter 47.13 in the favourite parameters section.

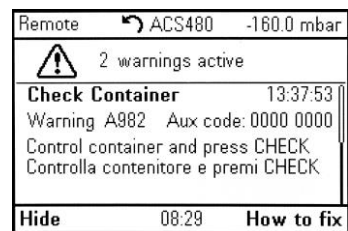

N.B. The last digit on the hours setting is a decimal. Therefore, to set 150 hours set the value at "1500".

The alarm can be reset by pressing the "Check" button on the back of the vacuum system (see Fig. 3 on page 13). In case there is a Brel module, when the alarm is tripped, the corresponding relay will be energised.

CHECK FILTER:

A second timer, as described above, will trip the "CHECK FILTER" alarm.

The preset timer can be changed using parameter 47.14 in the favourite parameters section.

N.B. The last digit on the hours setting is a decimal. Therefore, to set 300 hours set the value at "3000".



The alarm can be reset by pressing the "Check" button on the back of the vacuum system (see Fig. 3 on page 13). In case there is a Brel module, when the alarm is tripped, the corresponding relay will be energised.



**The vacuum system should always be powered.
The routine maintenance timers will be reset in case of power failure.**

5.7. Operation of the self-cleaning system

Models have a self-cleaning system for the filter that can operate at intervals programmable according to requirements, limiting maintenance to the replacement of the collection bag.

A timer controls the frequency of daily cleaning of the filter.

The operation of the device originates from a compressor that feeds a 7-litre air receiver tank with a preset pressure of up to 4-5 bar.

At the time set in the inverter (to change the time setting, see below), the system generates three high-pressure airshocks at two-minute intervals for a period of about six minutes. These airshocks clean the filter by blowing off the dust, which adheres to the outer walls of the filter, so it can fall into the dust container.

During the self-cleaning cycle, the vacuum system signals an "Autoclean ON" warning. The turbine continues to operate for the duration of the self-cleaning cycle to prevent dust from exiting the inlet ports located near the vacuum system.

This action keeps the filter clean for longer, thus reducing maintenance by the operator and ensuring better vacuum system performance.

The filter cleaning parameters pre-set by the manufacturer are as follows:





- One daily filter cleaning cycle
- Cleaning cycle duration: six minutes
- Cleaning cycle start time: 8:00 p.m.
- **Self-cleaning cycle with the turbine active**

The filter self-cleaning can occur either with the turbine in operation or with the turbine in stand-by.

Furthermore, for specific applications, up to eight fully programmable self-cleaning cycles can be activated.

To change these configurations, contact our technical department.

To change the filter self-cleaning cycle start time, proceed as follows:

1. Enter the parameters menu as described in section 5.4.
2. Select the "FAVOURITES" parameter list
3. Enter parameter 34.12 and change the start time using the arrow keys and press "save" ()
4. Return to the HOME screen using the "BACK/EXIT key." ()

MANUAL OPERATION

Press the Manual Self-Cleaning key to carry out a manual self-cleaning cycle (**see Fig. 3 on page 13**).

Looking at the pressure gauge located on the compressor, check that the tank has completely discharged the compressed air. Then refill the tank at a pressure of 4-5 bar using the compressor located at the back of the vacuum system.



Important: Do not open the dust collection container during the self-cleaning cycle. Wait at least one minute after the end of the cycle before opening it.

Perform the annual inspection of the filter to check its integrity and if it needs to be washed (once washed, the filter must be dry before it is reassembled).

All vacuum systems will signal a warning to check the filter status.

5.8. Impostazione lingua interfaccia utente

Using parameter 96.01, in the favourite parameters group, the desired language can be selected from the following: English, German, Italian, Spanish, Portuguese, Dutch, French, Danish, Finnish, Swedish, Russian, Polish, Czech, Hungarian and Turkish.



Select the interface language, highlight it (unless it is already highlighted) and then press the **SAVE** key 

NOTE: Once the language has been selected, stand by for a few minutes whilst the language file is downloaded to the control panel.

5.9. Operating Principle Definition

Using parameter **47.24**, the vacuum system's operating principle can be changed. There are two types of operations: whether to carry out the self-cleaning cycle with the turbine active or in stand-by can be set for each of these.

- **Traditional System:** Switching the vacuum system on or off by inserting or removing the working hose in the inlet port.
- **IWS System:** Switching on the system using the button on the handle. The system switches off automatically when all the inlet ports are closed.

Unless otherwise requested by the customer, all the vacuum systems are factory configured and tested using the **47.24=2** configuration, i.e., vacuum system using the traditional system and self-cleaning (if present) with turbine on. The table below shows the possible vacuum system configurations.

DEFINITION OF OPERATING PRINCIPLE		
Parameter Set	Description	Details
47_24 → 0	IWS Function + Self-cleaning with turbine OFF	Switch-off frequency to be set using 47_04 in HZ Switch-off delay to be set using 47_11 in seconds
47_24 → 1	STANDARD + Function Self-cleaning with turbine OFF	Direct start and delayed stop using 47_12 in seconds.
47_24 → 2	STANDARD + Function Self-cleaning with turbine ON	Direct start and delayed stop using 47_12 in seconds.
47_24 → 3	IWS Function + Self-cleaning with turbine ON	Switch-off frequency to be set using 47_04 in HZ Switch-off delay to be set using 47_11 in seconds

5.10. List of favourite parameters

The parameters in the favourites are divided into two groups:

- **User customisation parameters:**

All the parameters highlighted in grey in the table belong to this list. They can be changed by the end user without having to enter a password.

- **Central configuration parameters:**

The remaining parameters (not highlighted in grey) are password-protected and need to be enabled for modification. To change these parameters, enter the password “480” using parameter 96.02. After making the change, enter password “14” using parameter 96.02 to lock the parameters again.

Parameter	Description	Default value
34_12	Timer 1 start time	08:00:00 PM
40_21	Internal Set Point	-160mbar Lowest setting value -100mbar Highest setting value -200mbar
31_04	Event type External Event 2 “Check Container” “Check Container”	Warning (the inverter will trip the alarm but the vacuum system will continue to operate) By setting Fault in case of alarm the vacuum system will be stopped
31_10	Event type External Event 5 “Check Filter” “Check Filter”	Warning (the inverter will trip the alarm but the vacuum system will continue to operate) By setting Fault in case of alarm the vacuum system will be stopped
47_04	Data Memory 4 real32 “Switch-off frequency for wireless systems”	Varies according to the vacuum system model
47_11	Data Memory 1 int32 “Switch-off delay for wireless systems”	30 sec.
47_12	Data Memory 2 int32 “Switch-off delay for Standard systems”	5 sec.
47_13	Data Memory 3 int32 “Check Container”	1000 (set 1000 for a trip time at 100 hours)
47_14	Data Memory 4 int32 “Check filter”	3000 for a system without self-cleaning 5000 for a system with self-cleaning (set 2000 for a trip time at 200 hours)
47_24	Data Memory 4 int16 “Operating Mode”	See “OPERATING PRINCIPLE DEFINITION” table at section 5.9
96_01	Language	Italian (unless customised otherwise)
96_02	Password	480 (password to unlock all favourite parameters)

6. Maintenance

6.1. Routine maintenance

Accurate maintenance extends the operational life of the system and ensures constant performance over time, helping to prevent problems due to unexpected system blockings.



Before any maintenance isolate the central from the electric circuit. Lack of doing so exposes the operator to the risk of electroshock.

<i>Periodic operations</i>	<i>Normal Frequency</i>
Check filling level of the dust collector bag in the dust container	Every month
Check filter cartridge for possible clogging	Every month
Cleaning of filter cartridge (models without self-cleaning)	Every two month
Cleaning of filter cartridge (models with self-cleaning)	Biannually
Replacement of filter cartridge	2 years



The intervals between periodic maintenance operations may vary according to the type of use.

6.2. Replacement of dust collection bag

Dust collection bag inside the separator must be replaced in periodic intervals, as indicated in the “Periodic operations” chart on the previous page.



Before proceeding with replacement operations, a protective mask and gloves must be put on. Use only original spare bags supplied by General D'Aspirazione.



Failure to use these items of personal protection equipment may expose the operator to the risk of inhalation of dust that is harmful to health, or of the contact of allergenic substances with the skin.



While the dust container is being hooked up, there is the risk of cutting injuries to the fingers.



After completing any maintenance operation, remember that the vacuum unit must not be restarted without having first inserted the filter cartridge inside the separator.

The replacement procedure for the dust collection bag is as follows:

- Unhook the lower module of the separator by raising the bin handle.
- Extract the lower module of the separator by allowing it to slide on its wheels with the assistance of the specific handle.
- Extract the dust collection bag and replace it with a new one.
- Fold the edges of the bag towards the exterior.
- Hook up the dust container again to the separator. If it is necessary to move the dust container away from the separator to empty the dust collection bag, the vacuum tube that keeps the bag in the correct position must be unscrewed.

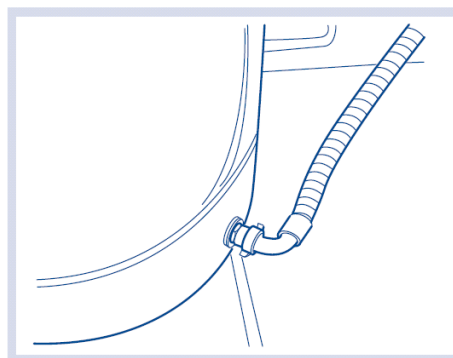
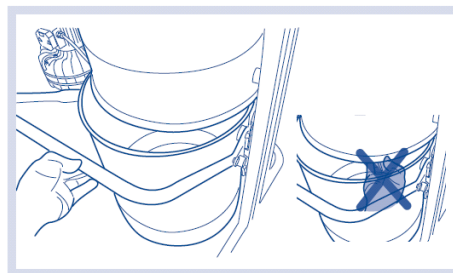

6.3. Replacement of the filter cartridge (Filter)

The filter cartridge must be checked and, if necessary, replaced when a progressive reduction of the suction power of the system is noted.

Replacement is always necessary after two years of use.



Before proceeding with replacement operations, a protective mask and gloves must be put on. Use only original spare bags supplied by General D'Aspirazione.



Failure to use these items of personal protection equipment may expose the operator to the risk of inhalation of dust that is harmful to health, or of the contact of allergenic substances with the skin.



While the dust container is being hooked up, there is the risk of cutting injuries to the fingers.



After completing any kind of maintenance operation, remember the suction unit must not be restarted without first having inserted the filter cartridge inside the separator.

The replacement procedure for the filter cartridge is as follows:

1. Unhook the lower module of the separator by raising the bin handle.
2. Extract the lower module of the separator by allowing it to slide on its wheels with the assistance of the specific handle.
3. Unscrew the black knob holding the filter cartridge in position.
4. Extract the filter cartridge.
5. When replacing the filter cartridge and make sure it is correctly installed (tighten the black knob accordingly).
6. Hook the dust bin back onto the separator by lowering the handle. If it becomes necessary to remove the dust bin from the separator, to empty the collection bag, the vacuum tube that allows the bag to be kept in the correct position must be unscrewed.

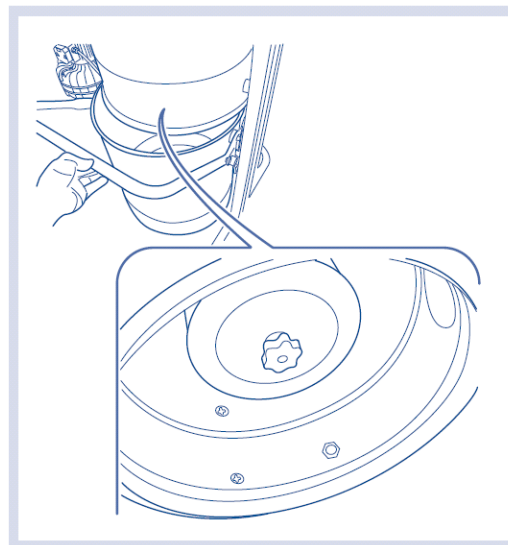

6.4. Cleaning of the filter cartridge (Filter)

The filter cartridge should be regenerated at the envisaged intervals (see section 6.1).



Before proceeding with replacement operations, a protective mask and gloves must be put on. Use only original spare bags supplied by General D'Aspirazione.



Failure to use these items of personal protection equipment may expose the operator to the risk of inhalation of dust that is harmful to health, or of the contact of allergenic substances with the skin.



While the dust container is being hooked up, there is the risk of cutting injuries to the fingers.

Extract the filter cartridge to be regenerated (see details of this operation in previous section), and if a replacement cartridge is available, use it to replace the cartridge to be cleaned. Clean the dirty cartridge with the vacuum unit, using the brush accessory for corners, taking care to avoid damage to the filter fabric. As an alternative, the filter can be washed with water.

If the filter fabric is damaged during cleaning operations, it is essential to replace the cartridge with a new one.



Use the filter cartridge only when it is completely dry.

After completing any kind of maintenance operation, remember the suction unit must not be restarted without first having inserted the filter cartridge inside the separator.

6.5. Non-routine maintenance

Extraordinary maintenance must be performed exclusively by authorised personnel.

The user can replace the remote panel battery by following the instructions below:

Inverter panel battery replacement

1. Turn the cover on the back of the control panel anti-clockwise until it opens.
2. Gently remove the battery.
3. Replace with a new CR2032 battery. The battery holder has small retainers. First slide the battery in on one side and then gently press down on the other side and the battery will snap in.
4. Make sure that the positive pole of the battery is facing upwards.
5. Replace the cover and tighten it down by turning it clockwise.
6. Discard the old battery in compliance with local battery disposal laws.

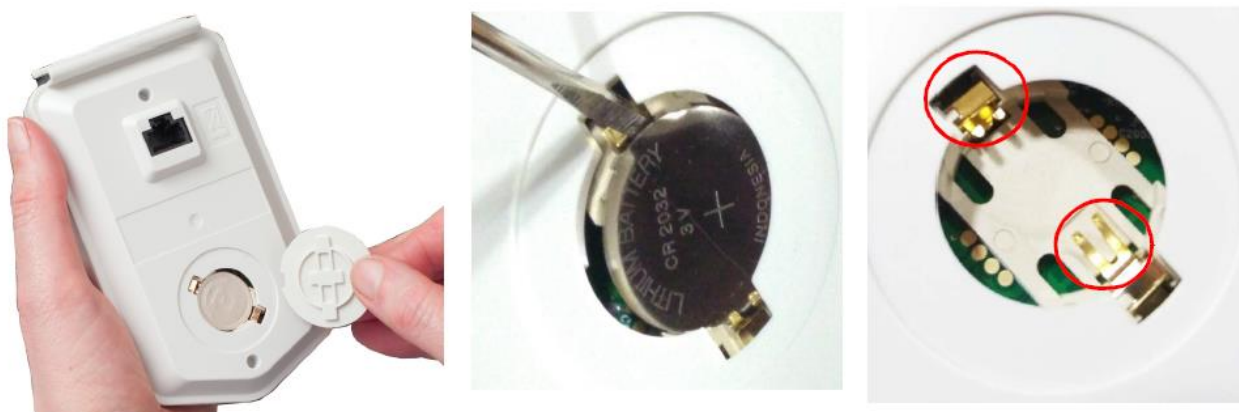

The manufacturer does not authorize the user of the system to perform the remaining extraordinary maintenance operations indicated below:



- Electronic programming
- Repairs / replacement of components
- Revisions
- Operational cycle changes
- Replacement of the power cable if damaged

it is necessary to send a request for intervention to the manufacturer's **Technical Assistance Service**

With the manufacturer's authorization, some operations can be performed by qualified personnel

Operations	Intervallo
Turbine maintenance	30.000h
Inverter maintenance	Every year
Maintenance of self-cleaning compressor	Every year
Maintenance of self-cleaning tank	Not necessary

7. Ricambi

Code	Description	
0216022	Separator polyester filter 120 litres	
0216034	Separator dust bag 120 litres	

8. Problems, causes and remedies

Inconvenient	Cause	Remedy
Absence of aspiration in all inlets	Power cord disconnected, inverter fault, vacuum disconnected from the system or excessive leakage along the pipeline.	Connect the power cord. Check for any faults generated by the inverter. Check for any leaks in the system and that the dust bin has been installed properly.
Consecutive and uninterrupted On / Off	Check for any defective outlets or false contacts in the system's electrical lines.	Change any defective outlets and/or resolve any false contacts in the system's electrical line
Failed start of the central from a single inlet	Electrical contacts interrupted	Control the electric contacts of the inlet and eventually replace
Weak or insufficient aspiration	Filter clogged	Clean or replace filter cartridge
	Simultaneous use of a number of inlets superior to the prescribed	Check the number of inlets in use
	Partial obstruction of the vacuum piping	Remove any blockages from the vacuum piping
	Air infiltration	Check that the dust bin and the bag retention tubing connections are tight
	Blocked air outlet	Remove eventual reason of clogging from the system
	Missing pressure	Leaks in the system or an inlet flap is not closing properly

	Cause	Remedy
When using the manual self-cleaning button and/or during the preset cycle, the self-cleaning does not work	Pressure switch in OFF position	Check that the compressor is in the auto position.
	Compressor and/or solenoid valve malfunction	Check that the fuses protecting the solenoid valve and the compressor are not blown.
		Contact technical office
Thermic intervention	Exhaust duct overheating.	Press the RESET button and check if the problem persists.
		Check that there are no obstructions in the system (whether in the vacuum pipe or in the outlet pipe)
		Check that the centralised vacuum system has not been used improperly nor for drawing in any impermissible dust
		Two-pole line coming from shorted outlets
		Make sure that the equipment room where the vacuum system has been installed complies with what is indicated herein.
	If the problem persists, contact your local authorised service centre.	
OTHER INVERTER SIGNALS	Contact technical office	

If the problems encountered are not listed in this Manual, it is necessary to contact the Service Center.



If the electric cable or the plug are defective, they have to be exclusively replaced by the manufacturer or the authorized after sales service or anyway by a person with similar qualification in order to avoid any risk.



If the commercial vacuum unit still operates incorrectly: Contact your dealer or distributor, who will indicate an authorized assistance centre – Indicate the serial number and model of your system. See Chapter 10 “PRODUCT GUARANTEE”



It is absolutely forbidden to carry out repairs and/or maintenance on the MONOBLOCK vacuum unit that are not authorized by this manual.

All repair operations for defects or malfunctions must be carried out only by qualified personnel from an assistance centre. If repairs or other operations are carried out by unauthorized personnel, the guarantee on the product will be invalidated, also exonerating the manufacturer from all and any liability in case of injuries and/or damage deriving from any such operations.

9. End of service and decommissioning

When the device has terminated its life cycle and must be decommissioned, follow these instructions to protect the environment:



The presence of this symbol on the product or on the pack indicates that the product must not be treated as normal household waste, but must be taken to a suitable collection centre for the recycling of electrical and electronic devices.

By disposing of this product correctly, you will help to avoid potentially harmful effects to the environment and to health that might be caused by disposing of it incorrectly.

For more detailed information on recycling procedures for this product, contact your local authority, your local waste disposal agency or the dealer from which the product was purchased.



Before proceeding with decommissioning and dismantling operations of any kind whatsoever, isolate the system from the electrical power supply line.

Failure to comply with this instruction may expose the operator to the risk of accidental starting or of electric shock.



During decommissioning operations, the appropriate items of personal protection equipment must be used.



Failure to use appropriate items of personal protection equipment during decommissioning and dismantling operations may expose the operator to the risk of crushing of the feet due to loss of stability.

Failure to wear safety gloves prevents a safe grip during disposal operations, with the risk of accidental falls.



During disposal and unpacking operations, the risk of crushing injuries may be present due to the loss of stability or falling of the machine.

Dismantling operations must be carried out only by qualified personnel.

Industrial wastes must normally be disposed of by companies accredited for their disposal.

If the machine is out of service due to malfunctions, repairs or failure to operate safely, it is advisable to warn of this with a notice.

10. Product guarantee

○ *Legal Guarantee*

The commercial vacuum units are covered by the "Legal Guarantee" required by European directives as implemented by Italian Legislative Decree 206/2005, on condition that they are used in conformity with the indications given in this Use and Maintenance Manual with regard to their intended use.



Important

The guarantee date refers to the date of the purchase invoice or receipt. The purchase document must therefore be kept to demonstrate the validity of the guarantee.

PART TO BE KEPT

PRODUCT DATA

Model

Serial

no.

Date of purchase

INSTALLER DATA

Business Name
(STAMP)

INSTALLATION
AND SYSTEM
TEST DATA

Family name

First name (s)

Street

Postcode

Town/city

Province

Tel /mob.

FAX

CUSTOMER DATA

Family name

First name (s)

Street

Postcode

Town/city

Province

Tel /mob.

FAX



- It is advisable to keep packaging materials for the entire period covered by the guarantee.
- For all problems, malfunctions or defects contact your dealer, who will provide you with details of an AUTHORIZED ASSISTANCE CENTRE.

11. CE Declaration of Conformity

Noi,

Manufacturer: General D'Aspirazione di Bianchi Claudia & C. s.a.s.
Address: Via del Lavoro, 9/11 – 47030 – San Mauro Pascoli (FC)

We declare under our full responsibility that the radio equipment

Model: 713T120AIB
Variations: 713T120IB - 595T120AIB – 595T120IB – 469T120AIB – 469T120IB –
350T120AIB – 350T120IB – 238T120AIB – 238T120IB

Firmware: Not present
Purpose of use: Central vacuum cleaner

Is conform to the essential requirements of the directive 2014/30/UE (EMC), the directive 2014/35/UE (LVD) and the directive 2011/65/UE (RoHS).

The product has been tested based on the following norms or technical specifics:

1. Directive 2014/35/UE of the European parliament and Counsel, of the 26th February 2014 , concerning the harmonisation of the legislations of the member states regarding the placement on the market of electrical material, destined for use within limits of tension. Relevant text for SEE purpose.
 - IEC 60335-1-2010+A1+A2 (SAF)
 - IEC 60335-2-2:2009+A1+A2 (SAF)
 - EN 62233:2008 (EMF/Health)
2. Directive 2014/30/UE of the European parliament and the counsel, of the 26th February 2014 , concerning the harmonisation of legislations of the member states regarding the electromagnetic compatibility (refusion) Relevant text for SEE purpose.
 - EN 55014-1:2021
 - EN 55014-2:2021
 - EN 61000-3-2:2019+A1
 - EN 61000-3-3:2013+A1+A2
3. Directive 2011/65/UE of the European parliament and counsel, of the 8th June 2011 , on the restriction of use of determined dangerous substances in electrical and electronic equipment Relevant text for Testo SEE purpose.
 - EN 50581:2012

Signature of the legal representative:



**GENERAL[®]
D'ASPIRAZIONE**
IMPIANTI ASPIRAPOLVERE CENTRALIZZATI